

# PORT-BASED MODELING OF MECHATRONIC SYSTEMS

**Peter Breedveld**

Control Engineering Laboratory, Drebbe Institute for Mechatronics and Faculty of Electrical Engineering,  
Mathematics and Computer Science, University of Twente, P.O. Box 217, 7500 AE Enschede, Netherlands  
tel.: +31 53 489 2792, fax: +31 53 489 2223, e-mail: P.C.Breedveld@utwente.nl

**Keywords:** bond graph(s), modelling and simulation, mechatronics, system(s)

## **Abstract**

Many engineering activities, including mechatronic design, require that a multidomain or ‘multi-physics’ system and its control system be designed as an integrated system. This contribution discusses the background and tools for a port-based approach to integrated modeling and simulation of physical systems and their controllers, with parameters that are directly related to the real-world system, thus improving insight and direct feedback on modeling decisions.

## **1. Introduction**

### *1.1. Port-based modeling of dynamic systems*

If modeling, design and simulation of (controlled) systems are to be discussed, some initial remarks at the meta-level are required. It should be clear and it probably will be, due to the way it is phrased next, that no global methodology exists that deals with each problem that might emerge. In other words, no theory or model can be constructed independent of some problem context. Nevertheless, in practice, (sub-)models of physical components are often considered as constructs that can be independently manipulated, for instance in a so-called model library. Without some reference to a problem context, such a library would be useless, unless there is an implicit agreement about some generic problem context. However, such a foundation is rather weak, as implicit agreements tend to diverge, especially in case of real world problems.

Herein, we will focus on the generic problem context of the dynamic (i.e. ‘changing in time’) behavior of systems that belong to the area of the engineer and the mechatronic engineer in particular, like the ones discussed in the examples. These systems can be roughly characterized as systems that consist for a large part of subsystems for which it is relevant to the dynamic behavior that they obey the basic principles of macroscopic physics, like the conservation laws and the positive-entropy-production principle. The other part consists of submodels for which the energy bookkeeping is generally not considered relevant for the dynamic behavior. Such parts are generally addressed as the signal processing part (‘controller’) that is commonly for a large part realized in digital form. This contribution focuses on the description of the part for which energy bookkeeping is relevant for the dynamic behavior, while keeping a more than open eye for the connection to the signal part, either in digital or in analogue form.

It is argued that port-based modeling is ideally suited for the description of the energetic part of a multidomain, sometimes also called multi-physics, system or subsystem. This means that the approach by definition deals with mechatronic systems and even beyond those.

Port-based physical system modeling aims at providing insight, not only in the behavior of systems that an engineer working on multidisciplinary problems wishes to design, build, troubleshoot or modify, but also in the behavior of the environment of that system. A key aspect of the physical world around us is that ‘nature knows no domains’. In other words, all boundaries between disciplines are man-made, but highly influence the way humans interact with their environment. A key point each modeler should be aware of is that any property of a model that is a result of one of his choices, should not affect the results of the model. Examples of modeler’s choices are: relevance of time and space scales, references, system boundaries, domain boundaries, coordinates and metric.

### *1.2. History*

Several attempts to unified or systematic approaches of modeling have been launched in the past. In the upcoming era of the large-scale application of the steam engine, the optimization of this multi-domain device (thermal, pneumatic, mechanical translation, mechanical rotation, mechanical controls, etc.) created the need for the first attempt to a systems approach. This need for such a ‘mechathermics’ approach was then named thermodynamics. Although many will not recognize a modern treatment of thermodynamics as the first systems theory, it certainly was aimed originally in trying to describe the behavior of such a system independently of the involved domains. However, it required a paradigm shift or ‘scientific revolution’ in the sense of Thomas Kuhn [14], due to the fact that the concept of entropy had to be introduced for reasons

of consistency, i.e. to be able to properly ‘glue’ these domains together with the concept of a conserved quantity called energy. The rather abstract nature of the concept of entropy, and to some extent the concept of energy too, has caused that students have considered thermodynamics a ‘difficult’ subject ever since, resulting in only a relatively limited number of engineers and scientists actively using the thermodynamic approach in modeling of system behavior and system design.

Despite the fact that the first evidence of the use of feedback dates back to 200-100 BC when water clocks required the water level in a reservoir to be kept constant, followed by Cornelis Drebbel’s thermostat and James Watt’s fly-ball governor, it was not before the late nineteen twenties that feedback was realized by means of electric signals (Harold Stephen Black’s 1927 famous patent that he wrote on a copy of the New York Times). At first, electronic feedback was used internally, to reduce distortion in electric amplifiers, but later, especially during World War II, this concept was used in radar control and missile guidance. One might say that the multidomain approach to feedback was transferred to a signal approach in which the external power supply did not need to be part of the behavioral analysis. However, a more important paradigm shift was still to come, viz. the idea that the use of feedback allowed the construction of components, viz. operational amplifiers, with which basic mathematical operations could be mimicked, leading to analogue computers. This gave a new meaning to the terminology ‘analogue simulation’ that until then was conceived as mimicking behavior by means of analogue circuits or mechanisms.

Just after World War II, due to the rapidly increasing demand for electric power, the USA was in great need for power plants, in particular hydropower plants, that should be able to deal with large and sometimes rapid fluctuations in the power grid. Obviously, the success of control theory (cybernetics) during World War II inspired many to apply control theory to the dynamic problems involved in electric power production.

One such a civil engineer by the name of Henry Paynter (Figure 1; <http://www.hankpaynter.com/>) tried to use the early analogue computers that he had invented together with James Philbrick, to simulate the dynamics of the power plants to be built (<http://www.me.utexas.edu/~lotario/paynter/paynterbio.html>). He used the at that time common description of block diagrams that display the computational structure of the differential and algebraic equations being used, as these mathematical operations were to be mapped directly on the basic components of the analogue computer. However, for reasons that will become clear in the course of this contribution (viz. related to the concept of so-called computational causality) he ran into formulation problems. At the beginning of the fifties he realized himself that the concept of a ‘port’ introduced in electrical circuit theory a few years earlier by Harold Wheeler [19], should be extended to arbitrary power ports that can be applied domain-independently. Power ports include mechanical ports, hydraulic ports, thermal ports, electric ports, etc., i.e. everything Paynter needed for the description of the dynamic behavior of power plants (<http://www.hankpaynter.com/Bondgraphs.html>).

In the following decade, after moving to the MIT mechanical engineering department, he designed a notation based on the efficient representation of the relation between two ports by just one line that he called a ‘bond’. This so-called ‘bond graph’ notation was completed when he finally introduced the concept of the junction in a lecture in 1959 [15]. Junctions not only make a bond graph a powerful tool, but they are rather abstract concepts that require another paradigm shift. Once this shift is made, it often induces over-enthusiasm and over-expectations that not only lead to disappointment, but also unnecessarily scare off experienced engineers and scientists who have learned to accept the limitations of modeling.

As a result, just like thermodynamics, bond graphs never became widely popular, although they spread over the whole world and are still alive and growing after more than forty years. By contrast, signal processing, analogue and later digital computing, were not constrained to physical reality. This allows mimicking virtually everything, from physically correct or incorrect models to arbitrary mathematical relations that described imaginary systems. In the previous decade, this even led to concepts like a ‘cyber world’, etc., even though the level of physical modeling in most virtual environments is rather low, as demonstrated by the unnatural features of much virtual behavior.

Nevertheless, the introduction of rapid and flexible machinery for production, assembly, manipulation (incl. surgery), etc., that has truly taken off in the nineties, raised the need for a systems approach again. In these application areas physical constraints still limit imagination. The dynamic behavior of such devices heavily leans on the application of digital electronics (microcomputers) and software, but a domain independent description of the parts in which power plays a role is crucial to make a designer aware of the fact that a

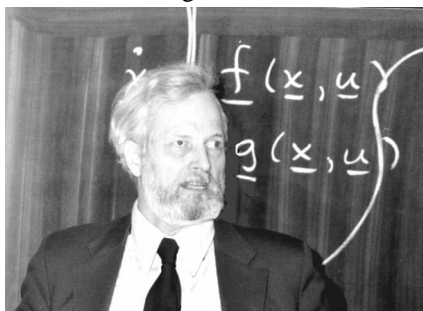

Figure 1: Prof. Henry M. Paynter

considerable part of these systems is constrained by the limits of the physical world. This mix of mechanics, or rather physical system engineering in general, at the one hand and digital electronics, software and control at the other hand has been named 'mechatronics'.

### **1.3. Tools needed for mechatronics**

Obviously, a smooth connection is needed between the information-theoretical descriptions of the behavior of digital systems and physical systems theory. Since their introduction bond graphs have allowed the use of signal ports, both in- and output, and a corresponding mix with block diagrams. As block diagrams can successfully represent all digital operations similar to mathematical operations, the common bond graph/block diagram representation is applicable. This graphical view supports a hierarchical organization of a model, supporting reusability of its parts.

However, many systems that are studied by (mechatronic) engineers differ from the engineering systems that were previously studied in the sense that the spatial description of complex geometries often plays an important role in the dynamic behavior, thus including the control aspects of these systems. This shows the need for a consistent aggregation of at the one hand the description of the configuration of a mechanism and at the other hand the displacements in a system that in some way are related to the storage of potential or elastic energy.

Another aspect of these systems is that only few realistic models can be solved analytically, emphasizing the important role of a numerical solution (simulation). The aggregation of numerical properties in the representation of dynamic systems allows that a proper trade-off is made between numerical and conceptual complexity of a model, however, without confusing the two. The approach discussed herein offers a basis for making such a trade-off, resulting in both a higher modeling efficiency and numerical simulation efficiency.

In mechatronics, where a controlled system is designed as a whole, it is advantageous that model structure and parameters are directly related to physical structure in order to have a direct connection between design or modeling decisions and physical parameters [9]. In addition, it is desired that (sub-)models be reusable. Common simulation software based on block-diagram or equation input does not sufficiently support these features. The port-based approach towards modeling of physical systems allows the construction of easily extendible models. As a result it optimally supports reuse of intermediate results within the context of one modeling or design project. Potential reuse in other projects depends on the quality of the documentation, particularly of the modeling assumptions.

### **1.4. Object-oriented modeling**

The port-based approach may be considered a kind of object-oriented approach to modeling: each object is determined by constitutive relations at the one hand and its interface, being the power and signal ports to and from the outside world, at the other hand. Other realizations of an object may contain different or more detailed descriptions, but as long as the interface (number and type of ports) is identical, they can be exchanged in a straightforward manner. This allows top-down modeling as well as bottom-up modeling. Straightforward interconnection of (empty) submodels supports the actual decision process of modeling, not just model input and manipulation. Empty submodel types may be filled with specific descriptions with various degrees of complexity –models can be polymorphic [17]– to support evolutionary and iterative modeling and design approaches [18]. Additionally, submodels may be constructed from other submodels resulting in hierarchical structures.

### **1.5. Design phases**

Often modeling, simulation and identification is done for systems that already exist. The design of a controller has to be done for an already realized and given 'process'. In case of a full design the system does not yet exist, which not only means that there is a large initial uncertainty, but also that there is much more freedom to modify the design, not just the controller, but the complete 'process', including the mechanical construction.

In a design process the following, iterative phases can be distinguished:

**Phase 1** A conceptual design is made of the system that has to be constructed, taking into account the tasks that have to be performed and identifying and modeling the major components and their dominant dynamic behaviors, as well as the already existing parts of the system that cannot be modified. The part of the model that refers to the latter parts can be validated already.

**Phase 2** Controller concepts can be evaluated on the basis of this simple model. This requires that the model is available in an appropriate form, e.g. as a transfer function or a state space description. If this phase provides the insight that modification of some dominant behavior would be quite beneficial, revisiting phase 1 can lead to the desired improvement.

**Phase 3** When the controller evaluation is successful, the different components in the system can be selected and a more detailed model can be made. The controller designed in phase 2 can be evaluated with the more detailed model and controller and component selection can be changed. If the effects of the detailed model prove to distort the originally foreseen performance, revisiting either Phase 2 or even Phase 1 with the newly obtained insights can lead to improved performance.

**Phase 4** When phase 3 has been successfully completed the controller can be realized electronically or downloaded into a dedicated microprocessor (embedded system). This hardware controller can be tested with a hardware-in-the-loop simulation that mimics the physical system ('plant') still to be built. It is to be preferred that the translation from the controller tested in simulations is automatically transferred to e.g. C-code, without manual coding; not only because of efficiency reasons, but also to prevent coding errors. If this phase results in new insights given the non-modeled effects of the implementation of the controller, the previous phases may be revisited, depending on the nature of the encountered problem.

**Phase 5** Finally the physical system itself can be built. As this is usually the most cost intensive part of the process, this should be done in such a way that those physical parameters that proved to be most critical in the previous phases are open for easy modification as much as possible, such that final tuning can lead to an optimal result.

Given the key role of structured, multi domain system modeling in the above process, special attention is given to domain-independent modeling of physical systems.

### **1.6. Multiple views in the design and modeling process**

Mechatronic design deals with the integrated design of a mechanical system and its embedded control system. In practice, this 'mechanical system' has a rather wide scope. It may also contain hydraulic, pneumatic and even thermal parts that influence its dynamic characteristics. This definition implies that it is important that the system be designed as a whole as much as possible. This requires a systems approach to the design problem. Because in mechatronics the scope is limited to controlled mechanical systems, it will be possible to come up with more or less standard solutions. An important aspect of mechatronic systems is that the synergy realized by a clever combination of a mechanical system and its embedded control system leads to superior solutions and performances that could not be obtained by solutions in one domain. Because the embedded control system is often realized in software, the final system will be flexible with respect to the ability to be adjusted for varying tasks.

The interdisciplinary field of mechatronics thus requires tools that enable the simultaneous design of the different parts of the system. The most important disciplines playing a role in mechatronics are mechanical engineering, electrical engineering and software engineering. One of the ideas behind mechatronics is that functionality can be achieved either by solutions in the (physical) mechanical domain, or by information processing in electronics or software. This implies that models for mechatronic systems should be closely related to the physical components in the system. It also requires software tools that support such an approach. In an early stage of the design process simple models are required to make some major conceptual design decisions. In a later stage (parts of the) models can be more detailed to investigate certain phenomena in depth. The relation to physical parameters like inertia, compliance and friction is important in all stages of the design. Because specialists from various disciplines are involved in mechatronic design, it is advantageous if each specialist is able to see the performance of the system in a representation that is common in his or her own domain. Accordingly, it should be possible to see the performance of the mechatronic system in multiple views. Typical views that are important in this respect are: Ideal physical models or 'iconic diagrams', bond graphs, block diagrams, Bode plots, Nyquist plots, state space description, time domain, animation, C-code of the controller.

This has been formalized as the so-called *multiple view approach* that is particularly well supported by window-based computer tools: a number of graphical representations like iconic diagrams, which are domain dependent, linear graphs, which are more or less domain-independent, but limited to the existence of analogue electric circuits [16], block diagrams, which represent the computational structure, bond graphs, which are domain independent, etc. as well as equations, which represent the mathematical form in different shapes (transfer functions, state space equations in matrix form, etc.) can serve as model representations in different windows. The tool in which all examples of this paper are treated, 20-sim, has been designed on the basis of such a multiple view approach. Possible views in 20-sim are: equations, including matrix-vector form, block diagrams, (multi-)bond graphs, transfer functions, state-space representations (system, in- and output matrices), time responses, phase planes, functional relationships, step responses, bode plots, pole-zero plots, Nyquist diagrams, Nichols charts and 3D-animation. Where possible, automatic transformation is provided and results are linked.

The port-based approach has been taken as the underlying structure of 20-sim, formulated in the internal language SIDOPS [8], which makes it the ideal tool for demonstration of the port-based and multiple view approaches. A more detailed introduction to ports, bonds and the bond graphs representation is given later. This will give the reader sufficient insight in order to exercise it with the aid of a port-based modeling and simulation software like 20-sim. This tool allows high level input of models in the form of iconic diagrams, equations, block diagrams or bond graphs and supports efficient symbolic and numerical analysis as well as simulation and visualization. Elements and submodels of various physical domains (e.g. mechanical or electrical) or domain-independent ones can be easily selected from a library and combined into a model of a physical system that can be controlled by block-diagram-based (digital) controllers. A demonstration copy of 20-sim that allows the reader to get familiar with the ideas presented in this contribution can be downloaded from the internet (<http://www.20sim.com>). For more advanced issues the interested reader is referred to the references. However, modeling is first treated in more generic terms.

## **2. Modeling philosophy**

### **2.1. *'Every model is wrong'***

This paradoxical statement seeks to emphasize that any model that perfectly represents all aspects of an original system is not a model, but an exact copy of that system (identity). When modeling one looks for simple but relevant analogies, not for complex identities. As a result, a model is much simpler than reality. This is its power and its weakness at the same time. The weakness is that its validity is constrained to the problem context it was constructed in, whereas its strength is the gain of insight that may be obtained in the key behaviors that play a role. In other words: 'no model has absolute validity'. The resulting advice is that one should always keep the limitations of a model in mind and always try to make them explicit first. Especially in an early phase of a modeling or design process, such a focus may result in interesting insights.

### **2.2. *'A model depends on its problem context'***

Models should be competent to support the solution of a specific problem. This also means that any type of archiving of a model or submodel should always include information about the corresponding problem context. Without this context, the model has no meaning in principle. Note that training of specialists and experts is often related to what is sometimes called a 'culture' and that they are said to speak a 'jargon'. This culture and jargon reflect the existence of a particular (global) problem context, even though this context is not explicitly described when models are made. For electrical circuit designers, this problem context consists of the behavior of electric charges and in particular of the voltages and currents related to this behavior, in a specific part of the space-time scale. This behavior is such that electromagnetic radiation plays no dominant role. Mechanical systems mostly belong to another part of the space-time scale, although there may be considerable overlap, in particular in precision engineering.

These cultures and jargons easily lead to implicit assumptions, which, in turn, may lead to model extrapolations that have no validity in the specific problem context at hand due to the danger of ignoring earlier assumptions. These extrapolations often start from well-known classroom problems with analytical solutions like the model of a pendulum [6]. In other words: 'implicit assumptions and model extrapolations should be avoided'. The resulting advice is that one should focus at the model's competence to represent the behavior of interest, not at its 'truth content'.

### **2.3. *Physical components versus conceptual elements***

In all cases it should be clear that (physical) components, i.e. identifiable system parts that can be physically disconnected and form a so-called physical, often visible, structure, are to be clearly distinguished from (conceptual) elements, i.e. abstract entities that represent some basic behavior, even though they are sometimes given the same name as the physical component. For example, a resistor may be an electrical component with two connection wires and some color code (cf. Figure 2a), while the same name is used for the conceptual element (commonly represented by Figure 2b) that represents the dominant behavior of the component with the same name, but also of a piece of copper wire through which a relatively large current flows.

Note that this model requires that the problem context is such that the component resistor is part of a current loop in a network in which the behavior of the voltages and currents plays a role. By contrast, other realistic problem contexts exist in which the dominant behavior of the component resistor is not represented by the element resistor, but by the element 'mass' or a combination of mechanical conceptual elements like mass, spring and damper. For example, when this component is to be rapidly manipulated in assembly processes, i.e. before it is part of an active circuit, this could be a competent model.

Often, not only the dominant behavior of a component has to be described but also some other properties that are often called ‘parasitic’, because they generate a conceptual structure and destroy the one-to-one mapping between components and elements that misleadingly seems to simplify modeling and design (cf. Figure 2c). Note that those areas of engineering in which materials could be manipulated as to suppress all other behaviors than the dominant one (like electrical engineering), have been the first to apply network style dynamic models successfully. Also note that in our daily life we have learned to make quick intuitive decisions about dominant behaviors (‘survival of the fittest’). This type of learning stimulates implicit and intuitive decisions that may fail in more complex engineering situations (counter-intuitive solutions). Implicit assumptions are commonly not only made about the problem context, but also about the reference, the orientation, the coordinates, and the metric and about ‘negligible’ phenomena. Famous classroom examples may have an impact on the understanding of real behavior for generations, especially due to the textbook copying culture that is the result of what may be called a ‘quest for truth’ motivation, ignoring model competence. A notorious example is the false explanation of the lift of an aircraft wing due to the air speed differences and resulting dynamic pressure differences in the boundary layer generated by the wing profile. This explanation has survived many textbooks, even though the simple observation that airplanes with such wing profiles can fly upside down falsifies this explanation in an extremely simple and evident way.

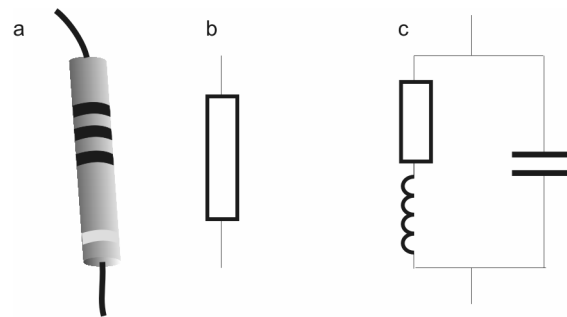

Figure 2: Component electrical resistor (a) with two different conceptual models (b & c)

Another example is a model of which the behavior changes after a change of coordinates: as coordinates are a modeler’s choice, they cannot have any impact on the behavior of the described system. Not keeping an open eye for these aspects of modeling may lead to exercises that are documented in the scientific literature in which controllers are designed to deal with model behaviors that are due to imperfections of the model and that are not observed at all in the real system or rather the actual problem context...

### 3. Ports in dynamic system models

#### 3.1. Bilateral bonds versus unilateral signals

The concept of a port is generated by the fact that submodels in a model have to interact with each other by definition and accordingly need some form of conceptual interface. In physical systems, such an interaction is always (assumed to be) coupled to an exchange of energy, i.e. a power. In domain-independent terminology, such a relation is called a power bond accordingly. This bilateral relation or bond connects two (power) ports of the elements or submodels that are interacting (Figure 3).

In the signal domain, this power is assumed to be negligible compared to the powers that do play a role, such that a signal relation may be considered a ‘unilateral’ relation. Note that ideal operational amplifiers have an infinite input impedance and a zero output impedance in order to suppress the back-effect and to be purely unilateral, but can only be approximated by adding external power. The bilateral nature of the power relations (as opposed to unilateral signal relations) suggest the presence of two variables that have some relation to the power represented by the bond. These so-called power-conjugate variables can be defined in different ways, but commonly they are related by a product operation to a power  $P$  and in the domain independent case named effort  $e$  and flow  $f$ :  $P = e \times f$ . Domain-dependent examples are force and velocity in the mechanical domain, voltage and current in the electrical domain, pressure and volume flow in the hydraulic domain, etc. In principle, the flow variable can be seen as the rate of change of some state, whereas the effort variable can be seen as the equilibrium-determining variable. Note that the common approach to use two types of storage, i.e. C- and I-type, prevents that this distinction between flow and effort as rate of change of state and equilibrium-determining variable respectively can be used in modeling straightforwardly. The so-called Generalized Bond Graph or GBG approach resolves this problem, leaving the discussion about the force-voltage versus force-current analogy a non-issue [2, 3], although there is a

clear didactical preference to introduce this approach using the force-voltage analogy [11]. This is not further discussed in order to adapt to the conventional background of the reader, despite the fact that the ‘rate of change’ versus ‘equilibrium-determining’ aspects of these variables are powerful tools to support initial modeling decisions.

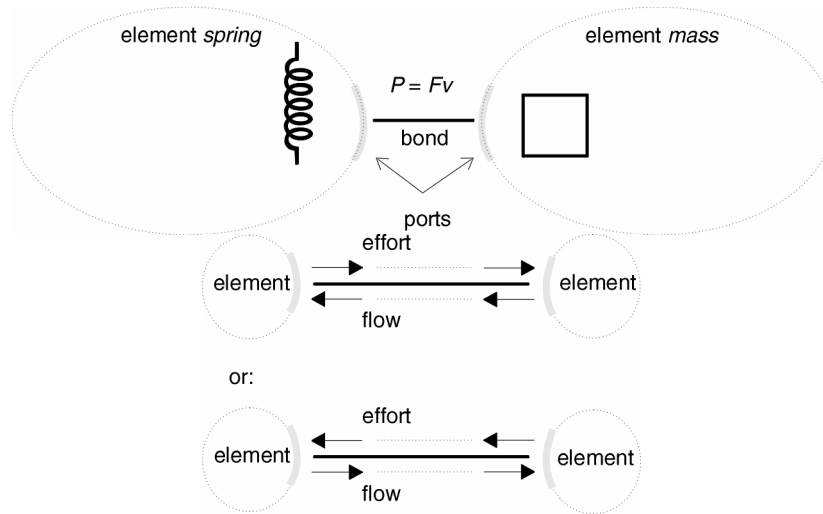

Figure 3: Bond connecting two ports

### 3.2. Dynamic conjugation versus power conjugation

The two signals of the bilateral signal flow representing a physical interaction are dynamically conjugated in the sense that one variable represents the rate of change of the characteristic physical property, like electric charge, amount of moles, momentum, while the other variable represents the equilibrium-determining variable. This is called dynamic conjugation. As long as no other domains are of interest, the concept of energy is not particularly relevant, such that these variables do not need to be related to a power like the effort and flow discussed earlier. Examples are: temperature and heat flow (product is not a power, heat is not a proper state if other domains are involved), molar flow and concentration or mole fraction (product is not a power), etc. The power-conjugated variables effort and flow are a subset of these dynamically conjugated variables.

This illustrates that the concept of a domain-independent conserved quantity, the energy, is crucial for the consistent interconnection of physical phenomena in different domains. The discussion of basic behaviors in section 6 is based on this and thus requires either the consistent use of power-conjugated variables or carefully defined domain transitions that are power continuous and energy conserving.

## 4. Computational causality

In pure mathematical terms one can state that a subsystem with a number of (power) ports, called multiport, is a multiple-input-multiple-output or MIMO system model, of which the set of inputs and the set of outputs is not a priori chosen. The relation between the input and output variables, the so-called constitutive relation, determines the nature of this multiport.

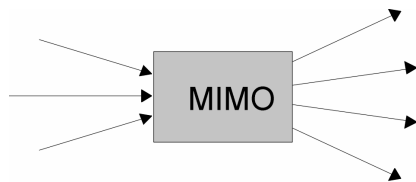

Figure 4a : conventional MIMO

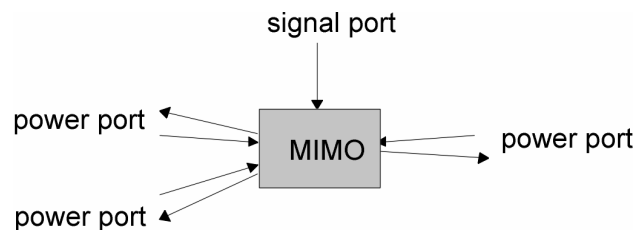

Figure 4b : MIMO system with bilateral power ports and modulating signal ports

If the number of input variables is not equal to the number of output variables, this means that there has to be at least one unilateral signal port as opposed to a bilateral power port as the latter is by definition characterized by one input and one output. If this signal port is an input signal, the multiport is called modulated. Modulation does not affect the power balance, in other words: no energy can be exchanged via

a signal port. Note that situations can exist in which the model is modulated although the number of inputs equals the number of outputs, because for each modulating signal there is a signal output.

Although ports and bonds illustrate that two bilateral signals are involved in a relation, no a priori choice about the direction of the corresponding signals needs to be made. This is an important distinction with a conventional MIMO system (Figure 4). A particular choice of this computational direction or causality is needed before a set of computable relations can be found or some particular analysis can be performed. Often, such a ‘causality assignment’ leads to computational forms that are not obvious and would have led to modeling problems in conventional approaches, in particular when domain boundaries are crossed (cf. the remarks about Paynter’s motivation in the introduction). As a result, bond causality does not only support the solution of computational and analytical issues, it also gives the modeler immediate feedback about the physical meaning of his modeling decisions and the trade-off he has to make between conceptual and computational complexity. If information about its causality is represented on a bond in a bond graph by means of a so-called ‘causal stroke’ (cf. Figure 5), the bond graph simultaneously represents physical and computational structure [4,12]. From the latter point of view a bond graph can be seen as a condensed block diagram. However, although any causal bond graph can be converted into a block diagram, the reverse does not hold, as physical structure is lost in the first transformation.

The causal stroke is attached to that end of the bond where the effort signal comes out, i.e. where it enters the connected port. This automatically means that the so-called open end of the bond represents the computational direction of the flow signal (cf. Figure 5).

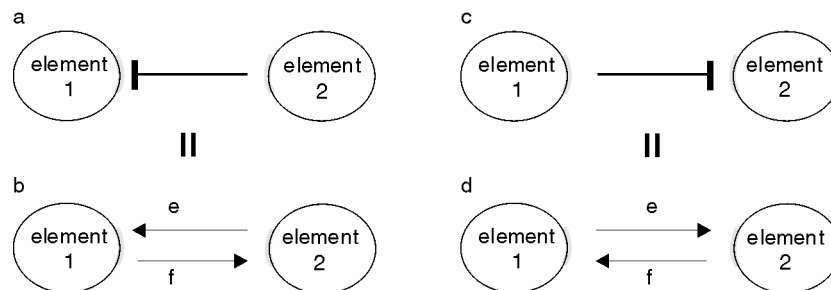

Figure 5: Causal stroke showing computational direction of effort signal

The trade-off between conceptual and computational complexity may be illustrated by the simple example of a rigid constraint between two rigid bodies. Conceptual simplicity leads to a causal problem (a so-called dependent inertia with differential causality) -the DC-servo system example already showed that a loop emerges containing an integration and a differentiation, i.e. a ‘net’ algebraic loop (cf. Figure 14)- and consequently to numerical complexity (DAE). A DAE is a mixed set of differential and algebraic equations that cannot be solved straightforwardly by means of explicit numerical integration (e.g. with the common Runge-Kutta 4th order method). However, the way in which the causal problem emerges in the model during causal analysis (to be discussed in section 8) clearly suggests how the model can be modified in order to prevent the causal problem. In this example the rigid constraint can be replaced by an elastic element, i.e. a finite rigidity. Although this gives the model some more conceptual complexity, the numerical (structural) complexity is reduced, due to the fact that the resulting equations are a set of ordinary differential equations (ODE) that can be solved by explicit numerical integration schemes [1], see also the course slides at <http://www.npac.syr.edu/users/gcf/CPS615NI95/>.

Note that the model still needs a rather stiff constraint and thus introduces dynamics at a time scale that is not of interest. This means not only means that both options to formulate the model can be a solution depending on the problem context, the available tools, etc., but also that a third solution can be obtained, viz. a symbolic transformation of the model as to eliminate the dependent inertia. In other words: two rigidly connected rigid bodies may be considered as one rigid body. This possibility is also induced by the causal analysis of the bond graph model that will be discussed in section 8.

## 5. System versus environment: system boundary

The distinction between system and environment is determined by the role of these parts: the environment can influence the system, but not dynamically interact with it. In signal terminology: the environment may influence the system via inputs and observe the system via outputs, but the inputs cannot depend on these outputs at the time scale of interest. In case of normal use, a car battery for example, may be considered the environment of a dashboard signal light, as the discharge will not affect the voltage in a considerable way. In other words, the car battery in this problem context (regular car use) can be modeled by a voltage source.

However, in a context of a car being idle for three months (other time scale!) the car battery has to be made part of the system and dominantly interacts with the resistance of the bulb like a discharging capacitor. The resulting RC-model is competent in this problem context to predict the time-constant of the discharge process. In severe winter conditions the thermal port of this capacitor will have to be made part of the system, etc.

Note that, after a particular choice of the separation between environment and system, the influence of the environment on the system may be conceptually concentrated in this system boundary by means of so-called sources and sinks, also called boundary conditions or constraints, depending on the domain background. They are part of the ideal conceptual elements to be discussed next.

## 6. Elementary behaviors and basic concepts

This section introduces the conceptual elementary behaviors that can be distinguished in the common description of the behavior of physical systems, in particular from a port-based point of view. Before the individual elements are discussed, first the notation for the positive orientation in the form of the so-called half-arrow is introduced.

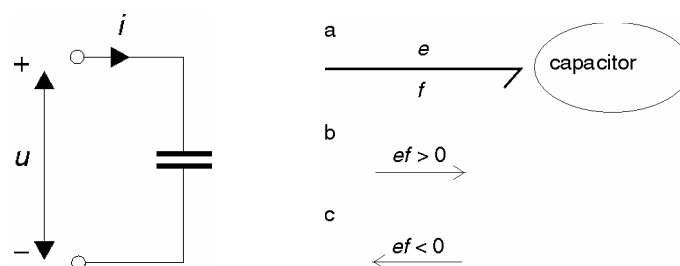

Figure 6: Positive orientation represented by a half arrow, direction depends on sign (b,c)

### 6.1. Positive orientation and the half-arrow

Each bond represents a connection between two ports. However, with one loose end it can be used to visualize the port it is connected to. The three variables involved, effort, flow and power, may have different signs with respect to this port. In order to be able to indicate this, a *half arrow*, as opposed to the full arrow that is commonly used for signals, is attached to the bond, expressing the positive orientation of these variables, similar to the plus and minus signs and the arrow that are used for an electric two-pole to represent the *positive orientation* of the voltage and the current respectively (Figure 6). Note that the half-arrow does *not* indicate the *direction* of the flow or the power: the direction is opposite in case the corresponding variable has a negative value (Figure 7).



Figure 7: Half-arrow does not influence causality

Like the causal stroke the half-arrow is an additional label to the bond, but they do not influence each other. The causal stroke merely fixates the direction of the individual signal flows in the bilateral signal flow pair, whereas the half-arrow merely represents positive orientation.

### 6.2. Storage

The most elementary behavior that needs to be present in a system in order to be dynamic is 'storage'. In mathematical terms one can describe this behavior by the integration of the rate of change of some *conserved quantity*, viz. the stored quantity or *state*, and by the relation of this state with the equilibrium determining variable, the so-called *constitutive relation*. Note that in the common classification of domains, many domains are characterized by two types of state, viz. the generalized displacement and the generalized momentum, following the common approach in the mechanical domain. It has been noted before that another classification of domains that for instance separates the mechanical domain into a kinetic domain and a potential or elastic domain can easily resolve the paradoxical situation that results from the common choice [3], but this would be beyond the scope of this contribution. This means that the common two types of storage are used:

1. the C-type storage element in which the flow is integrated into a generalized displacement and related to the conjugate effort

2. the I-type storage element in which the effort is integrated into a generalized momentum and related to the conjugate flow.

Note that both are dual in the sense that they can be transformed into each other by interchanging the roles of the conjugate variables effort and flow.

Simple examples of C-type storage elements are:

- ideal spring (mechanical domain)
- ideal capacitor (electric domain, Figure 8)
- ideal reservoir (hydraulic/pneumatic domain)
- ideal heat capacitor (thermal domain)

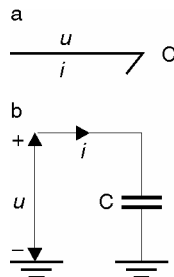

Figure 8: Bond graph representation of an electrical capacitor

Note that the explicit use of the adjective ‘ideal’ tries to emphasize the difference between elements and components although the naming is usually based on the component that dominantly displays a particular elementary behavior.

Simple examples of I-type storage elements are:

- ideal mass (mechanical domain)
- ideal inductor (electric domain)
- ideal fluid inertia (hydraulic/pneumatic domain)

Storage elements can be used in a domain independent way due to the built in representation of the energy conservation principle. Not only the stored quantity, e.g. charge, matter, momentum, flux linkage, etc. is stored, but also the energy related to this storage. In case that more than one quantity is stored (multi-port storage) the principle of energy conservation supports the description of the potential *power transfer* from one domain into the other by means of *cycle processes*. Almost all engineering transduction processes can be related to this concept and usefully analyzed with the tools that thermodynamics provides, even when the model contains no thermal port. For instance, the insight that a set of two coupled coils, i.e. the component ‘transformer’, does not transform DC is easily explained this way [7]. Note that all other parts of a system have to satisfy the principle of energy conservation too. However, no storage takes place there, so it can be concluded at this point that all remaining basic elements have to be power continuous in principle, apart from external sources and sinks that represent the interaction with the environment, in which energy is ‘stored’ or ‘released’ without keeping track of it.

### 6.3. Irreversible transformation

Next to the first law of thermodynamics, the second law of thermodynamics has to be satisfied. However, the entropy production is assumed to take place only in the two-port irreversible transformers that are usually addressed as one-port ‘dissipators’ or ‘resistors’ due to the fact that the thermal port can be omitted if the temperature is assumed to be homogenous and constant at the time scale of interest. Note that this implicit assumption is often not explicitly mentioned, which may lead to modeling inconsistencies, as these one-ports are clearly power discontinuous.

As the rest of the system has to satisfy the second principle too, all entropy production is assumed zero there, which results in entropy continuity for all elements except for the storage elements where *reversible* storage of entropy is allowed. Note that ‘reversible storage’ is a tautology, as irreversibilities would violate the basic concept of storage, but is used here to make the distinction with the irreversible production. The common acronym for an irreversible transducer is RS, derived from the common acronym in the isothermal case, R, to which an S for source is added to represent the entropy production.

Simple examples of irreversible transforming (resistive) elements are:

- ideal electric resistor
- ideal friction
- ideal fluid resistor
- ideal heat resistance

Due to the second principle of thermodynamics (positive entropy production), the relation between the conjugate variables at the R-port can be linear or nonlinear as long as the relation remains in the 1st and 3rd quadrant. However, the relation at the S-port (always in the thermal domain) is intrinsically nonlinear, due to the absolute zero-point of temperature.

#### **6.4. Reversible transformation**

Irreversible transformation more or less suggests the ‘possibility’ of, or rather the need for, the ideal concept of a reversible transducer. As they cannot store or produce entropy, as these properties are already concentrated in the RS elements, they have to be power continuous. Their most elementary form is the two-port. It can be formally proven that, independent of the domain, only two types of port-asymmetric, i.e. with non-exchangeable ports, power-continuous two-ports can exist, at the one hand the so-called transformer (acronym: TF) that relates the efforts of both ports and also the flows of both ports and at the other hand the so-called gyrator (acronym: GY) that relates the flow of one port with the effort of the other vice versa. Furthermore, the nature of the relation is multiplicative, either by a constant (regular TF and GY) or by an arbitrary time-dependent variable, the so-called modulating signal (acronyms: MTF and MGY). The notion of a port-asymmetric multiport will be clarified when port-symmetric multiports are discussed.

Simple examples of reversible transforming elements are:

- ideal (or perfect) electric transformer
- ideal lever
- ideal gear box
- ideal piston-cylinder combination
- ideal positive displacement pump

Simple examples of reversible gyrating elements are:

- ideal centrifugal pump
- ideal turbine
- ideal electric motor

An ideal continuously variable transmission is a simple example of a reversible, modulated transforming element, while an ideal turbine with adjustable blades is a simple example of a reversible, modulated gyrating element.

In port-based models of planar and spatial mechanisms specific types of (configuration-)state-modulated (multiport) transformers play a crucial role, which exposes the dual role of the displacement variable once more.

#### **6.5. Supply & demand (sources & sinks / boundary conditions)**

As already announced, the supply and demand from and to the environment can be concentrated in the (conceptual!) system boundary and represented by sources or sinks. As sinks can be considered negative sources, only ideal sources are used as ideal elements. Given that a port has two kinds of variables, effort and flow, two kinds of sources may exist, Sources of effort and Sources of flow (acronyms: Se and Sf). Generally speaking, all storage elements that are large compared to the dynamics of interest (note that this cannot be considered independently of the resistance of its connection to the rest of the system) may be approximated by infinitely large storage elements that are identical to sources. An infinitely large C-type storage element becomes an Se, an infinitely large I-type storage element becomes an Sf. However, feedback control may turn a port into a source, cf. a stabilized voltage source too. As the voltage may be adapted or modulated, these kinds of sources are called modulated sources (MSe, MSf).

Simple examples are of (modulated) effort sources are:

- ideal (controlled) voltage source
- ideal (controlled) pressure source, etc.

Simple examples are of (modulated) flow sources are:

- ideal (controlled) current source
- ideal (controlled) velocity source, etc.

#### **6.6. Distribution**

In order to be able to distribute power between subsystems in an arbitrary way, distributing elements with three or more ports are required. By assigning all energy storage to the storage elements, all entropy production to the irreversible transducers (‘dissipators’) and all exchange with the environment to the sources, only the property of power continuity remains. Furthermore, the requirement that ports should be connectable at will, requires that an interchange of ports of these distributing or interconnecting elements

has no influence. This is the so-called property of port-symmetry. It is important to note that it can be formally proven that only the requirements of power continuity and port symmetry result in two solutions, i.e. two types of multiports (i.e. interconnection elements with two or more ports) with constitutive relations that turn out to be linear, the so-called junctions. The constitutive relations (one per port) of the first type require all efforts to be identical and the flows to sum up zero with the choice of sign related to their positive orientation, similar to a Kirchhoff current law. Paynter called this junction a zero-junction, due to the similarity between the symbol for zero and the shape of a node, because like a node in an electric circuit (at that time the only network type notation) the 0-junction has a common effort and the adjacent flows sum to zero (flow balance).

The constitutive relations of the second type, called 1-junction, are dual: all flows should be identical and the efforts sum to zero with the choice of sign related to their positive orientation (effort balance), similar to a Kirchhoff voltage law.

However, it is a mistake to say that the junctions represent the generalized Kirchhoff laws, as the junctions at the same time represent the ‘commonness’ of the power-conjugate variable, such that they can be used at the same time to represent that particular variable, which is quite convenient during modeling.

As mentioned before, really manipulating the concept of the junction in a way that supports the modeling process, i.e. without using other modeling techniques and translation first, requires some skill as the true understanding of the junctions requires the paradigm shift mentioned earlier. Nevertheless, the results are powerful, as will be demonstrated after the discussion of the causal port properties.

## 7. Causal port properties

Each of the nine basic elements (C, I, R(S), TF, GY, Se, Sf, 0, 1) introduced above has its own causal port properties, that can be categorized as follows: fixed causality, preferred causality, arbitrary causality and causal constraints. The meaning of these categories will become clear when the basic elements are discussed. The representation by means of the causal stroke has been introduced already (cf. Figure 5).

### 7.1. Fixed causality

It needs no explanation that a source of effort always has an effort as output signal, in other words, the causal stroke is attached to the end of the bond that is connected to the rest of the system (Figure 9, 10a). Mutatis mutandis the causal stroke of a flow source is connected at the end of the bond connected to the source (Figure 10b). These causalities are called ‘fixed causalities’ accordingly. Apart from these fundamentally fixed causalities, all ports of elements may become nonlinear and non-invertible, i.e. all but the junctions, may become fixed due to the fact that the constitutive relation may only take one form. In more advanced causal analysis procedures, the distinction between these two types of fixed causalities is used [10]. Herein, this distinction will not be made for the sake of clarity, as it is not relevant for most simple models.

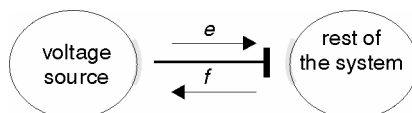

Figure 9: Fixed effort-out causality of an effort (voltage) source



Figure 10: Fixed causality of sources

### 7.2. Preferred causality

A less strict causal port property is that one of the two possibilities is, for some reason, preferred over the other. Commonly this kind of property is assigned to storage ports, as the two forms of the constitutive relation of a storage port require either differentiation with respect to time or integration with respect to time (Figure 11). On the basis of numerical arguments the integral form is preferred, due to the fact that numerical differentiation amplifies numerical noise, but there are more fundamental arguments too. A first indication is found in the fact that the integral form allows the use of an initial condition, while the differential form does not. Obviously, an initial state or content of some storage element is a physically relevant property that illustrates the statement that integration ‘exists’ in nature, whereas differentiation does not. Although one should be careful with the concept existence when discussing modeling, this statement seeks to emphasize that differentiation with respect to time requires information about future

states in principle, whereas integration with respect to time does not. The discussion of causal analysis will make clear that violation of a preferred causality gives important feedback to the modeler about his modeling decisions. Note that some forms of analysis require that the differential form is preferred, but this requirement is never used as a preparation for numerical simulation.

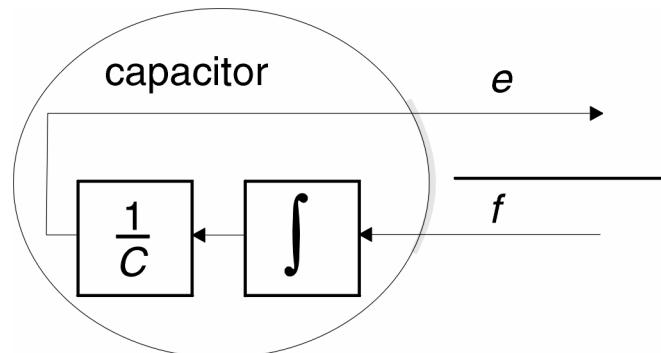

Figure 11: Preferred integral causality of a capacitor

### 7.3. Arbitrary causality

The expected next possibility in the sequence is that the causality of a port is neither fixed nor preferred, thus arbitrary. Examples of arbitrary port causality are linear, thus invertible, resistive ports. For example, the acausal form of the constitutive relation of an ohmic resistor is  $u - Ri = 0$ , the effort-out causal form is  $u = Ri$ , while the flow-out causal form is  $i = u/R$  (cf. Figure 15).

### 7.4. Causal constraints

Causal constraints only exist for basic multiports, i.e. elements with two or more ports like the transducers (TF, GY) and the junctions (0,1). For instance, if the constitutive relation of the two-port transducers is linear (the junctions are intrinsically linear), the first port to which causality is assigned is arbitrary, but the causality of the second port is immediately fixed. For instance, the two-port transformer always has one port with effort-out causality and one with flow-out causality. By contrast, the causalities of the ports of a two-port gyrator always have the same type of causality. In graphical terms: a TF has only one causal stroke directed to it, while a GY has either both causal strokes directed to it or none.

The fundamental feature of the junctions that either all efforts are common (0-junction) or all flows are common (1-junction) shows that only one port of a 0-junction can have 'effort-in causality' i.e. flow-out causality, viz. the result of the flow-balance. By contrast, only one port of a 1-junction can have 'flow-in causality' i.e. effort-out causality, viz. the result of the effort-balance. In graphical terms: only one causal stroke can be directed towards a 0-junction, while only one open end can be directed towards a 1-junction.

## 8. Causal analysis: feedback on modeling decisions

Causal analysis, also called causality assignment or causal augmentation, is the algorithmic process of putting the causal strokes at the bonds on the basis of the causal port properties induced by the nature of the constitutive relations. Not only the final result, but also the assignment process provides immediate feedback on modeling decisions.

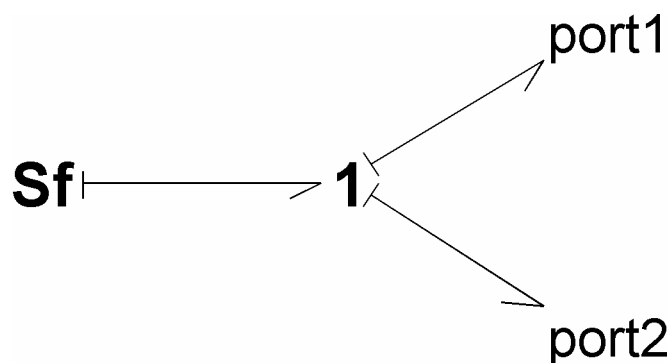

Figure 12: Propagation of a fixed causality via a 1-junction

### 8.1. Fixed causality

Obviously, the first step in this process is to assign fixed causalities and immediately propagate them via the causal constraints. For instance, if a flow source is connected to a 1-junction, the source-port immediately gets flow-out causality, which in turn means that the corresponding port at the 1-junction gets flow-in causality, which means that all other ports of the 1-junction get flow-out causality, etc. (Figure 12). Conflicts at this stage of the causality assignment procedure indicate that the problem is ill posed, e.g. two voltage sources in parallel or two force sources trying to impose the same force (mechanically ‘in series’). Note that the causality propagation may lead to violation of preferred causalities, e.g. a voltage source in parallel to a capacitor or a velocity source on a mass. This violation gives the modeler the feedback that no independent state is related to the storage element as its content is imposed by a source, which also means that it is dynamically inactive. In fact, not only storage ports, but also resistive ports that get their causality imposed by a source are dynamically inactive, as they cannot form signal loops (causal paths) via other ports.

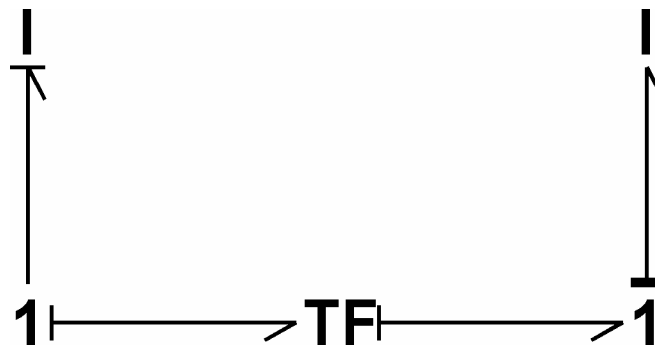

Figure 13: Dependent inertia's via de causal constraints of 1-junctions and transformer

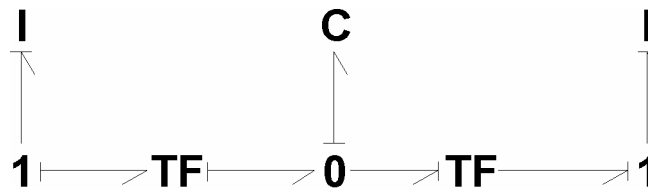

Figure 14: Independent inertia's by adding the elasticity of the transmission (e.g. belt-drive)

### 8.2. Preferred causality

Naturally, the fixed causalities are followed by the preferred causalities that are similarly propagated via the causal constraints. Conflicts at this stage indicate that a port may get differential causality as a result of another port getting preferred integral causality. Figure 13 shows the bond graph of the two inertia's in a servo system model, including the transmission (TF), but without any compliance. This shows the modeler that he has chosen a model in which two storage ports depend on each other and form a signal loop (causal path) with an integration that is compensated by a differentiation, i.e. a net algebraic loop. The computational problem may be solved by the application of implicit numerical integration, by changing the model (the sequence of putting the causal strokes hints the modeler where a model change should be made, e.g. adding a spring between the two rigid bodies; figure 14), or by symbolic manipulation (either manually or automatically) of the model. A technique to deal with this problem by adding some advanced control schemes to the model is under investigation. This also changes the model, but not in a way that can be physically interpreted [13].

### 8.3. Arbitrary causality

Commonly all ports in a bond graph are causal after assigning and propagating fixed and preferred causalities, but if this is not the case, it means that at least two ports with arbitrary causality are present. If an arbitrary choice is made for one of these ports, this means that at least one other port will obtain its causality as a result of propagation via the causal constraints. The dual choice would have the same effect. This shows the modeler that this situation always results in an algebraic loop (or its reverse form) that may

cause numerical difficulties (cf. Figure 15). In the same way as in case of differential causality, the assignment procedure itself hints the modeler how to change the model in order to prevent the loop. Note that the causality assignment process is completely algorithmic and more advanced variations on this algorithm exist and are implemented that can handle all possible situations [10]. As a result, it can be used without using the notation itself, e.g. by replacing the bond graph by e.g. the more common iconic diagram representation or the linear graph notation. However, this largely reduces the amount of feedback that can be given to the modeler about his modeling decisions and the effect of model modifications becomes less obvious. Nevertheless, if one is merely interested in converting a simple iconic diagram into code ready for simulation, this is a powerful option. It will be exploited in the second part as the scope of this paper only allows some intuitive exposure to the bond graph notation.

#### 8.4. Example of causal analysis

The bond graph in figure 17 represents a simple linear model of the servo-system containing a belt drive given in figure 16. It is graphical input to 20-sim. This software puts the causal strokes automatically, and immediately while drawing the graph. The order in which the strokes are put can be indicated by sequence numbers, where  $i.j$  represents the  $j$ th propagation of putting stroke  $i$ .

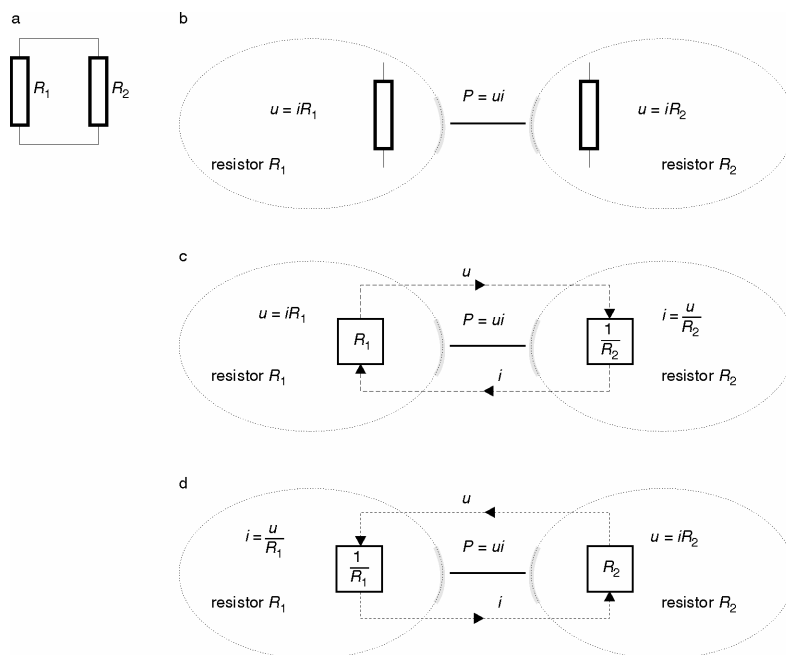

Figure 15: Arbitrary causality of two resistors causing an algebraic loop

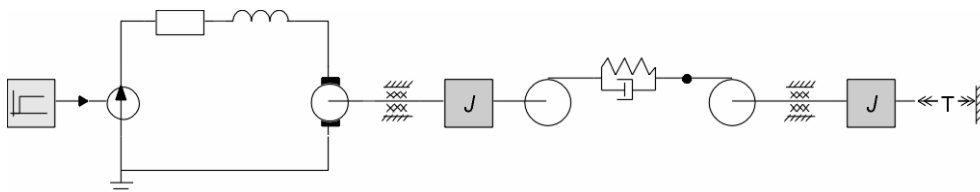

Figure 16: Iconic representation of a servo system with belt drive (graphical 20-sim input)

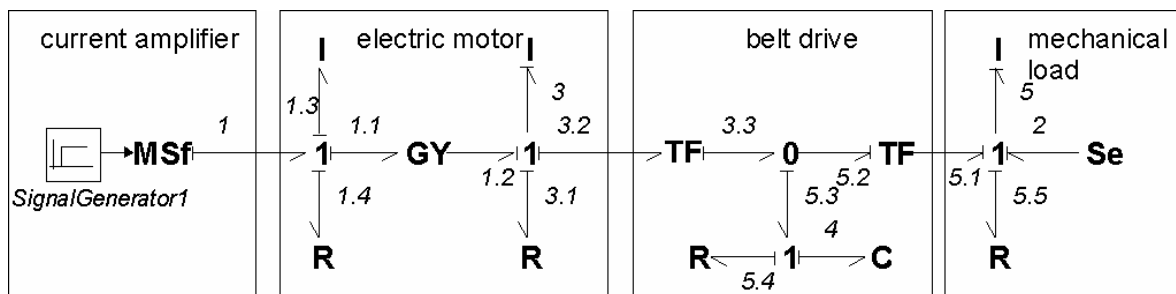

Figure 17: Simple, linear bond graph model of the servo system in figure 16

Note that the fixed causalities are Sf (1) and Se (2), where only Sf propagates via the 1-junction and imposes causality to the electrical I and R and the electrical port of the GY, thus eliminating the electrical time constant that would have been present in the model if the electrical source would have been a voltage source. The propagation stops at the next 1 junction, after the mechanical port gets its causality via the constraint of the GY (1.2). The preferred causalities are the remaining storage elements, i.e. the inertia of the rotor (I 3), the compliance of the belt (C 4) and the inertia of the mechanical load (I 5). The motor inductance (I 1.3) plays no dynamic role as its current is imposed and its voltage (that is computed by differentiation does not affect the current amplifier (Sf 1), like the motor voltage (GY 1.1) and the ohmic voltage drop in the circuit (R 1.4). Propagation of the motor inertia (I 3) reaches as far as the 0-junction representing the force in the belt and propagation of the inertia of the load completes the causality of this graph. Note that following causal strokes through the graph (causal path) identifies the existence of signal loops.

## 9. Example of the use of the port concept

Only the actual use of the port-concept can fully clarify its importance. Therefore, a simple case study is discussed to illustrate it. A component that may be used in mechatronic systems, viz. a control valve, but in which the control is not realized by (digital) electronic signal processing, but physically, i.e. as an energetic process, is taken as an example. This choice is made in order to focus on the multidisciplinary modeling part on the basis of power ports.

### 9.1. Problem context

Under some operating conditions of a low-vacuum control valve (cf. Figure 18) spontaneous, self-sustained oscillations occur [5]. Given the purpose of the valve, viz. to maintain a constant ‘low’ vacuum in particular in medical applications, this behavior is clearly undesired. In order to solve this problem insight is to be obtained in the source(s) of this behavior and the design parameters of the system that should be modified in order to prevent it. Some simple oscilloscope measurements of these oscillations, mainly showing shape and frequency, are available to the modeler as well as a construction drawing of the valve with data on geometry and used materials.

### 9.2. Functional description of the valve

The intended basic operation of this control valve is that an orifice can be opened and closed by a valve body that is connected to a diaphragm loaded by a coil spring. Changing the position of the other end of this spring with a screw knob can set its pretension. The diaphragm is part of the wall of the valve chamber that is at one end connected to the ‘supply’ pressure (a relatively high under pressure or ‘vacuum’) via the valve opening and at the other end via an orifice and a hose to the ‘mouth piece’ to suck superfluous body fluids away as used by dentists and surgeons. Given some desired low under pressure or ‘low-vacuum’, the pressure difference over the diaphragm will cause the valve opening to get smaller if the actual pressure gets too low compared to the desired pressure. Due to the increasing flow resistance of the variable orifice the pressure difference with the supply pressure (‘high’ vacuum) will increase again vice versa.

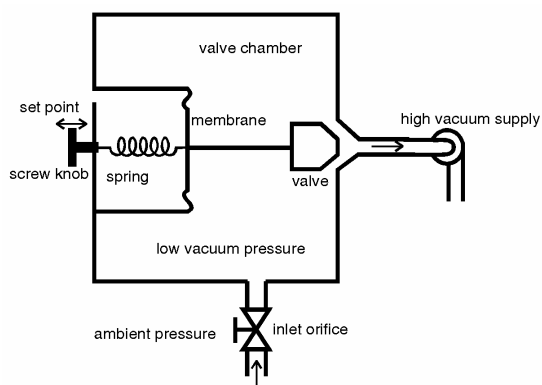

Figure 18: Sketch of the low-vacuum control valve

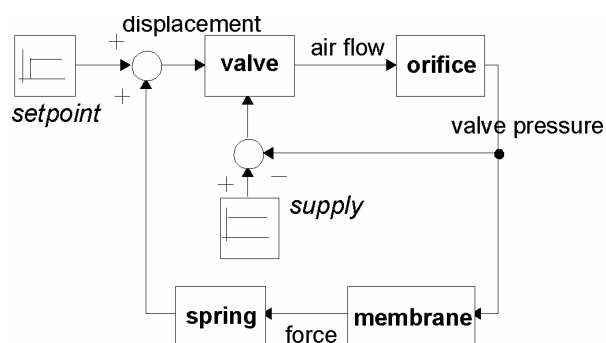

Figure 19: Algebraic model resulting from functional description

### 9.3. Analysis

If this common functional explanation is translated into a block diagram, it becomes clear that the resulting model is not dynamic at all (Figure 19) as all relations are algebraic. If oscillations occur it is tempting to identify a damped second order system consisting of the valve body, the spring and the mechanical damping that is always present. As such a model is not competent to explain sustained oscillations, it seems obvious to argue that the airflow is likely to drive these oscillations. The next step that seems obvious is to conclude that the common chaotic behavior of flow phenomena (turbulence) that is hard to model deterministically is likely to form the onset of the oscillations, such that no attempt is made to create a competent dynamic model and the problem is approached in an ad hoc way by changing the geometry of the valve by trial and error.

However, if one approaches this problem from a port-based point of view the analysis will make a distinction between power relations and modulation and leads to another result, not only of the analysis, but also of the actual physics that play a role in such a valve.

In a regular valve a screw modulates the position of the body of the valve. Note that the fluid acts with a force on this body, trying to move it out of the valve seat. The reason that the fluid cannot displace the valve body while the human hand can do this, is the presence of the transforming action of the screw/spindle. This amplifies the static friction of the screw seen from the translating port of the screw/spindle. However, as this static friction is only overcome during a hand turning the valve and the dynamics of this process are at a completely different time scale than the flow phenomena in the valve, a change in position of the valve body is commonly modeled as a modulation of the flow resistance of the valve. Hence, a position-modulated resistor can describe the dominant behavior of an arbitrary valve. Figure 20 shows how the ports and port properties of such a valve can be defined in 20-sim, without having to define the exact constitutive relations yet.

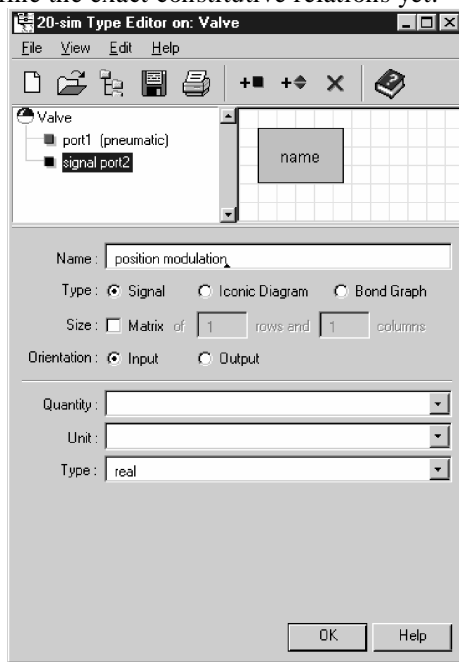

Figure 20: Definition of ports in 20-sim

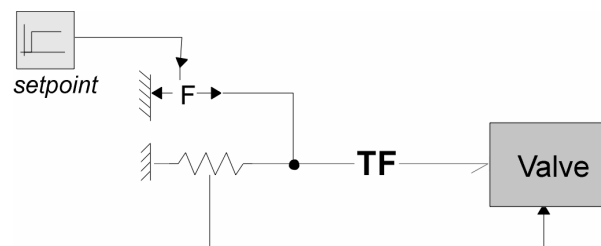

Figure 21: Mix of block diagram, iconic diagram and bond graph representation (20-sim editor screen)

Feedback can be introduced by a diaphragm (membrane) that transforms the difference in pressure at its sides into a force that can cause a displacement. By connecting the body of the valve to the membrane such that an increasing pressure difference will close the valve and a decreasing pressure difference will open it, it will thus have a counteraction in both cases, i.e. a negative feedback. The relation between force and displacement is characterized by the stiffness of the diaphragm. It needs to be increased in order to attenuate the position changes of the valve body. This is achieved by connecting a spring. By connecting the other end of the spring to the screw, the screw can be used to change the setpoint for the pressure difference by changing its pretension. The screw serves as a combination of a (Coulomb) friction and a transformer that amplifies its effect similar to the regular valve described above. The model of the complete

valve has to be at least extended by an ideal transformer (TF) to represent the dominant behavior of the diaphragm, an ideal spring to represent the elasticity of the spring and the diaphragm and a modulated force source to introduce the pretension of the setpoint. Figure 21 shows this with a mixed use of bond graph (TF, valve), block diagram (modulation and signal generator) and iconic diagram elements (spring, force source and fixed world).

Note that the source of the pressure difference described earlier hasn't been accurately defined. One might conclude that the pressure difference between some supply pressure and the ambient pressure is meant as these are the two obviously present pressures. However, this would cause the output pressure to fluctuate with the supply pressure, which is commonly not desired. Furthermore, the output pressure is required to cause some fluid exchange with the environment, i.e. some flow connection to the environment. As a consequence one is usually interested in setting the pressure difference between the output pressure and the supply pressure. This means that the valve needs to contain a more or less closed volume, the so-called valve chamber in which the output pressure is allowed to be different from both the supply and the ambient pressure. Obviously, some opening needs to connect this chamber to the environment in order to allow the desired flow. The dominant behavior of this restriction is that of an ideal (fluid) resistor, whether a hose is attached to the orifice or not. Parasitic behavior as fluid inertia (in case of a long hose) may be added later when fine-tuning the model. Summarizing, the following ideal elements are required in the model: a position-modulated resistor, a transformer, a spring and a resistor (Figure 22). As the spring is the only dynamic element (containing an integration with respect to time) in this model, oscillatory solutions are not likely.

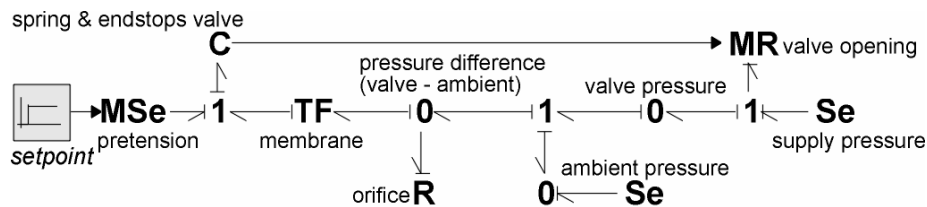

Figure 22: Addition of boundary conditions, flow resistor and structural details (pressures)

Note that the labeled nodes in the bond graph merely represent the elementary behaviors, while their exact constitutive relations have not been determined yet. Some of them will be non linear though. If the ambient pressure is chosen as the reference pressure (zero-point) all pressures will obtain negative values in a low-vacuum control valve, but the bond graph is simplified into the one in figure 23.

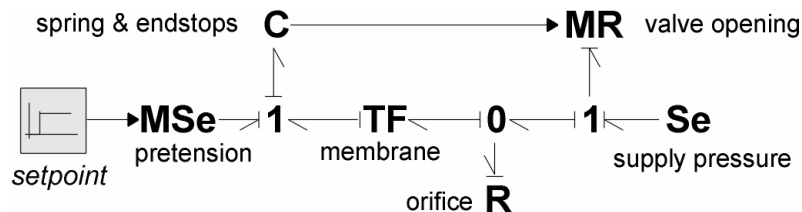

Figure 23: Simplification by choosing ambient pressure as reference pressure

Note that the flows through the resistors are mainly dictated by the pressures imposed by sources except for the contribution to the valve chamber pressure by the spring. It can be concluded that a linearization around an operating point leads to a first order model characterized by a time constant. At this point one might be inclined to bring the possibility of oscillatory behavior into the model by adding an ideal mass to represent the dominant behavior of the valve body. Together with the ideal spring it forms a (damped) second order system that has the potential of oscillatory solutions. However, such oscillations are not self-exciting and not self-sustained, unless the system would contain negative damping which would violate the laws of physics. Note the change of position of some of the causal strokes (automatically generated by 20-sim) and the causal path from the R to the valve that indicates an algebraic loop (Figure 24).

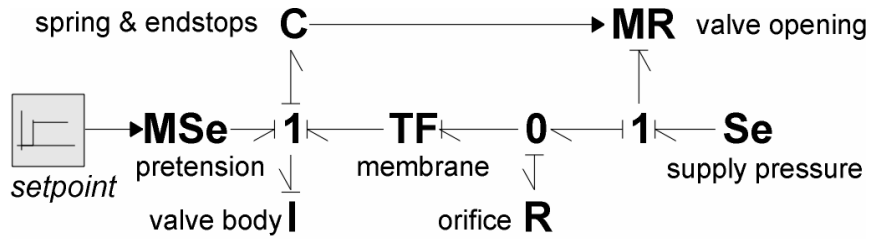

Figure 24: Addition of the valve body mass

The causality assignment process hints the modeler to put a C-type storage element at the 0-junction representing the pressure in the valve chamber in order to prevent this algebraic loop. This element represents the compressibility of the air in the valve chamber (Figure 25) and will appear crucial to obtain a model that is competent to represent self-sustained oscillations.

Figure 26 shows that this model contains a third order loop via the position modulation of the valve and a causal path. It can be interpreted as follows: the position that modulates the valve is (inversely) proportional to the flow through the valve. The capacitance of the valve chamber relates the displaced volume (first integration!) of this flow to the pressure in the chamber. Via the diaphragm this pressure acts with a force on the valve body. The resulting change of its momentum (second integration!) results in a change of its velocity. Finally this velocity causes its displacement (third integration!) and thus results in the position that modulates the valve resistor (closure of the loop). Under certain conditions this third order loop may have unstable solutions that are bounded by the nonlinearities of the model, like the valve body hitting the valve seat (end stops that can be added to the model easily, but discussion is beyond the scope of this paper). The causality of the ports is derived automatically by 20-sim while drawing this graph and automatically results in a computable set of equations for simulation. The same procedure is used in case of iconic diagrams and other representations that contain the concept of a port, although in those cases the immediate feedback that a third order loop is present cannot be obtained immediately.

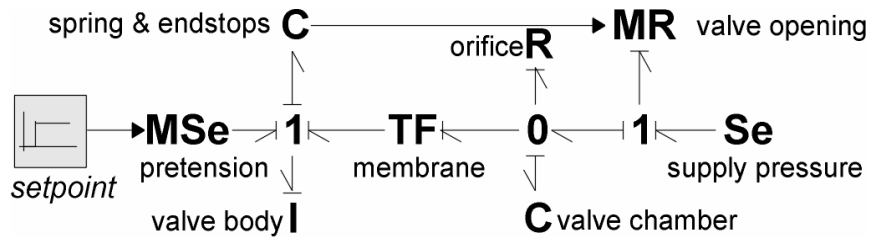

Figure 25: Addition of the compressibility of the air in the valve chamber (C)

At this point, this example should illustrate that modeling should be focused on the relevant elementary behaviors present in a system, not merely on a (one-to-one) translation of the functional relations as the designer of the valve intended them, because this would never bring in the compressibility of the air in the valve chamber. The key elements in this model to represent the observed behavior are: the nonlinear, position-modulated resistor, the valve body, the diaphragm and the capacitance of the valve chamber to create the third order loop, but also the spring with its adjustable pretension, the fluid resistor at the inlet, the supply pressure and the valve body hitting the valve seat. The number of elementary one- and multiports is relatively small.

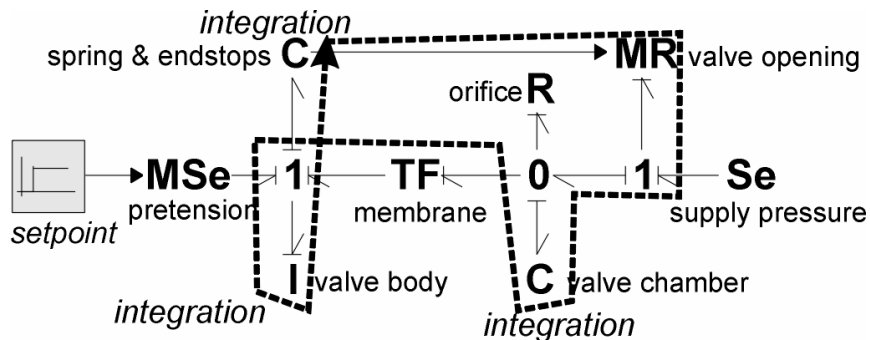

Figure 26: Third order loop (three integrations) via a causal path and the modulation signal

After identification of the proper parameter values from the provided measurement data, first simulation runs showed indeed self-starting and self-sustained oscillation with a shape that coincided with the shapes observed on the oscilloscope. The frequency of these first results was only 10% off the observed frequency. Fine-tuning of the model allowed these frequencies to be matched. However, the actual problem was already solved before the parameter identification phase, because the process of setting up the model structure already indicated the crucial role of the valve chamber that was confirmed by an experienced senior craftsman at the work floor where these valves were produced and assembled. He then remembered that long ago the role of this valve chamber was identified by trial and error. A result that had been forgotten over the years and didn't play a role in the design of the new valve that was causing the oscillation problems.

After this discussion, it should be clear that a bond graph without modulating signals can never result in three integrations in a loop. A causal path can only exist between at most two storage elements, such that the number of integrations in the corresponding signal loop is at most two. Hence, the modulating signal of the valve that contains a third integration is also one of the crucial elements to create a model that is competent to represent the instabilities.

Note that the possibility of the oscillations that can result from the third order loop is inherent to this particular type of design. None of the parts can be omitted or changed as to break the third order loop. For this reason, every designer of such valves should have the insights discussed above in order to be able to choose the dimensions of the valve such that it never displays undesired behavior in or near the range of operation. This insight is more related to model structure than to particular simulation results, although simulation results can help to identify the influence of the valve chamber size on the modes of operation.

Similar types of valves are not only used as low-vacuum control valves, but also as fuel-injection valves, pressure reduction valves, etc.

This example demonstrates that a port-based approach provides this insight quite easily, although the use of this approach should be supported by sufficient knowledge of engineering physics.

## 10. Conclusion

This paper has shown how modern object-oriented modeling of physical systems can help to make proper decisions during the design of mechatronic systems and to create more insight in the physics of the object to be modeled. This approach enables to easily change from finding solutions in the controller domain or in the mechanical structure itself. Software tools that cover the different domains support this process.

Emphasis was on the background of physical modeling in general. In particular the paradigm shift to the port-based approach via the introduction of the concepts of a port and a junction were discussed. An example demonstrated that one of the major achievements is that a tool allowing a multiple-view approach provides insight into the nature and background of the observed behavior. A bond graph representation gives the user who gained some expertise in this language feedback about his modeling decisions via the representation of computational causality by the causal stroke. Note that the port-based computational causality assignment procedure is also used in the iconic diagram notation, but cannot provide the graphical insight that is obtained via a bond graph, as the control valve example illustrated. As the approach focuses on insight, it is particularly suited for education [7]. All sorts of generalizations like multi-bond graphs, Generalized Bond Graphs, bi-causality, hybrid systems, etc. exist, but are beyond the scope of this paper. The interested reader is referred to the extensive literature on these topics.

## 11. References

- [1] U.M. Ascher and L.R. Petzold, *Computer Methods for Ordinary Differential Equations and Differential-Algebraic Equations* (SIAM, ISBN 0-89871-412-5, 1998).
- [2] P.C. Breedveld, Thermodynamic Bond Graphs and the problem of thermal inertance, *J. Franklin Inst.*, Vol. 314, No. 1 (1982) 15-40.
- [3] P.C. Breedveld, *Physical Systems Theory in terms of Bond Graphs*, ISBN 90-9000599-4, 1984.
- [4] P.C. Breedveld, *Fundamentals of Bond Graphs*, in: *IMACS Annals of Computing and Applied Mathematics*, Vol. 3: *Modelling and Simulation of Systems*, Basel, 1989, 7-14.
- [5] P.C. Breedveld, Bond-graph modeling of a low-vacuum control valve, in: P.C. Breedveld and G. Dauphin-Tanguy, eds., *Bond Graphs for Engineers*, IMACS Transaction Series, (Elsevier, Amsterdam, 1992, ISBN 0 444 89707 0) 135-150.
- [6] P.C. Breedveld, On state-event constructs in physical system dynamics modeling, *Simulation Practice and Theory*, Vol. 7 (5-6) (1999) 463-480.

- [7] P.C. Breedveld, Integrated Modeling of Physical systems, part 1-3, in preparation, preliminary versions on request, 2003.
- [8] A.P.J. Breunese, Automated support in mechatronic systems modelling, Ph.D. thesis, University of Twente, Enschede NL, ISBN 90-365-0872-X, 1996.
- [9] H.J. Coelingh, Design Support for Motion Control Systems, Ph.D.-thesis, University of Twente, Enschede, NL, also [www.ce.el.utwente.nl/clh/](http://www.ce.el.utwente.nl/clh/), 2000.
- [10] G. Golo, Interconnection Structures in Port-based Modelling: Tools for Analysis and Simulation, PhD Thesis, University of Twente, Twente University Press, ISBN 9036518113, 2002.
- [11] N. Hogan, and P.C. Breedveld, The Physical Basis of Analogies in Physical System Models, in: R.H. Bishop, ed., The Mechatronics Handbook, (CRC Press, Boca Raton, Fl., 2002, ISBN 0-8493-0066-5) 15.1-15.10 (Chapter 15).
- [12] D.C. Karnopp and R.C. Rosenberg, System Dynamics: A unified Approach (Wiley, New York, 1975).
- [13] P.A.J. Koenders, On the relation between equation formulation of constrained systems and implicit numerical integration and optimization, M.Sc. Thesis, University of Twente, Control Engineering, 2001.
- [14] T.S. Kuhn, The Structure of Scientific Revolutions, (University of Chicago Press, 1962) <http://www.emory.edu/EDUCATION/mfp/Kuhnsnap.html>, 1962.
- [15] H.M. Paynter, Analysis and Design of Engineering Systems, (MIT Press, 1961).
- [16] J.L. Shearer, A.T. Murphy and H.H. Richardson, Introduction to System Dynamics, (Addison Wesley, New York, 1971).
- [17] T.J.A. de Vries, Conceptual design of controlled electro-mechanical systems, Ph.D.-thesis, University of Twente, Enschede, Netherlands, 1994.
- [18] P.B.T. Weustink, T.J.A. de Vries and P.C. Breedveld, Object Oriented Modelling and Simulation of Mechatronic Systems with 20-sim 3.0, in: J. Adolfson and J. Karlsén, eds., Mechatronics 98, (Elsevier Science Limited, 1998).
- [19] H.A. Wheeler and D. Dettinger, Wheeler Monograph 9 (1949) 7.