

IDA-PBC controller for a bidirectional power flow full-bridge rectifier*

Carles Batlle
MAIV, EPSEVG and IOC,
Univ. Politècnica de
Catalunya
08800 Vilanova i la G., Spain
carles.batlle@upc.edu

Arnau Dòria-Cerezo
Dept. of Electrical Eng.,
EPSEVG and IOC,
Univ. Politècnica de
Catalunya
08800 Vilanova i la G., Spain
arnau.doria@upc.edu

Enric Fossas
ESAIL, ETSEIB and IOC,
Univ. Politècnica de
Catalunya
08028 Barcelona, Spain
enric.fossas@upc.edu

Abstract—A controller able to support bidirectional power flow in a full-bridge rectifier with boost-like topology is obtained. The controller is computed using port Hamiltonian passivity techniques for a suitable generalized state space averaging truncation of the system, which transforms the control objectives, namely constant output voltage dc-bus and unity input power factor, into a regulation problem. Simulation results for the full system show the correctness of the simplifications introduced to obtain the controller.

I. INTRODUCTION

Variable structure systems (VSS) are piecewise smooth systems, *i.e.* systems evolving under a given set of regular differential equations until an event, determined either by an external clock or by an internal transition, makes the system evolve under another set of equations. VSS appear in a variety of engineering applications [17], where the non-smoothness is introduced either by physical events, such as impacts or switchings, or by a control action, as in hybrid or sliding mode control. Typical fields of application are rigid body mechanics with impacts or switching circuits in power electronics.

Port controlled Hamiltonian systems (PCHS), with or without dissipation, generalize the Hamiltonian formalism of classical mechanics to physical systems connected in a power-preserving way [16]. The central mathematical object of the formulation is what is called a Dirac structure, which contains the information about the interconnecting network. A main feature of the formalism is that the interconnection of Hamiltonian subsystems using a Dirac structure yields again a Hamiltonian system [5]. A PCH model encodes the detailed energy transfer and storage in the system, and is thus suitable for control schemes based on, and easily interpretable in terms of, the physics of the system [8] [10].

PCHS are passive in a natural way, and several methods to stabilize them at a desired fixed point have been devised [11]. On the other hand, VSS, specially in power electronic applications, can be used to produce a given periodic power signal to feed, for instance, an electric drive or any other

power component. In order to use the regulation techniques developed for PCHS, a method to reduce a signal generation or tracking problem to a regulation one is, in general, necessary. One powerful way to do this is averaging [7], in particular what is known as Generalized State Space Averaging, or GSSA for short [12]. In this method, the state and control variables are expanded in a Fourier-like series with time-dependent coefficients; for periodic behavior, the coefficients will evolve to constants. In many practical applications [6], physical consideration of the task to solve indicates which coefficients to keep, and one obtains a finite-dimensional reduced system to which standard techniques can be applied.

In this paper we apply PCHS techniques to a GSSA model of a boost-like full-bridge rectifier. This problem was already studied in [6] for the case of a constant sign load current. However, in many applications, such as the control of doubly-fed induction machines [2], power can flow in both directions through the back-to-back (rectifier+inversor) converter connected to the rotor. Since the aim of the control scheme is to keep the intermediate dc-bus to a constant voltage, this means that the rectifier's load current can have any sign (although it can be supposed to be, approximately, piecewise-constant in time). Hence the need for a different solution than that found in [6] arises. It should be noticed that standard procedures to solve the bidirectional case cannot be applied, since, no matter which output is chosen, either dc-bus voltage or ac-current, the zero dynamics is unstable for one of the modes of operation [13][1].

The paper is organized as follows. In Section II basic formulae of the PCHS description and the GSSA approximations are presented. Section III presents the full-bridge rectifier, its PCHS model and the GSSA approximation of interest for the problem at hand. Section IV computes a controller using IDA-PBC techniques, and Section V presents numerical simulations of the controller for the full model of the converter. Finally, Section VI states our conclusions and points to further improvements and to the experimental validation.

*This work has been done in the context of the European sponsored project Geoplex with reference code IST-2001-34166. Further information is available at <http://www.geoplex.cc>. Carles Batlle and Enric Fossas have been partially supported by the Spanish projects DPI2002-03279 and DPI2004-06871-CO2-02, and Arnau Dòria-Cerezo by DPI2004-06871-CO2-02.

II. GENERALIZED AVERAGING FOR PORT CONTROLLED HAMILTONIAN SYSTEMS

As explained in the Introduction, this paper uses results which combine the PCHS and GSSA formalisms. Detailed presentations can be found in [5], [15], [8] and [11] for PCHS, and in [4], [9], [12] and [14] for GSSA.

A VSS system in explicit port Hamiltonian form is given by

$$\dot{x} = [\mathcal{J}(S, x) - \mathcal{R}(S, x)] (\nabla H(x))^T + g(S, x)u, \quad (1)$$

where S is a (multi)-index, with values on a finite, discrete set, enumerating the different structure topologies. The state is described by $x \in \mathbb{R}^n$, H is the Hamiltonian function, giving the total energy of the system, \mathcal{J} is an antisymmetric matrix, describing how energy flows inside the system, $\mathcal{R} = \mathcal{R}^T \geq 0$ is a dissipation matrix, and g is an interconnection matrix which yields the flow of energy to/from the system, given by the dual power variables $u \in \mathbb{R}^m$ and $y = g^T (\nabla H)^T$.

Averaging techniques for VSS are based on the idea that the change in a state or control variable is small over a given time length, and hence one is not interested on the fine details of the variation. Hence one constructs evolution equations for averaged quantities of the form

$$\langle x \rangle(t) = \frac{1}{T} \int_{t-T}^t x(\tau) d\tau, \quad (2)$$

where $T > 0$ is chosen according to the goals of the problem.

The GSSA expansion tries to improve on this and capture the fine detail of the state evolution by considering a full Fourier series. Thus, one defines

$$\langle x \rangle_k(t) = \frac{1}{T} \int_{t-T}^t x(\tau) e^{-jk\omega\tau} d\tau, \quad (3)$$

with $\omega = 2\pi/T$ and $k \in \mathbb{Z}$. The time functions $\langle x \rangle_k$ are known as index- k averages or k -phasors.

Under standard assumptions about $x(t)$, one gets, for $\tau \in [t-T, t]$ with t fixed,

$$x(\tau) = \sum_{k=-\infty}^{+\infty} \langle x \rangle_k(t) e^{jk\omega\tau}. \quad (4)$$

If the $\langle x \rangle_k(t)$ are computed with (3) for a given t , then (4) just reproduces $x(\tau)$ periodically outside $[t-T, t]$, so it does not yield x outside of $[t-T, t]$ if x is not T -periodic. However, the idea of GSSA is to let t vary in (3) so that we really have a kind of ‘‘moving’’ Fourier series:

$$x(\tau) = \sum_{k=-\infty}^{+\infty} \langle x \rangle_k(t) e^{jk\omega\tau}, \quad \forall \tau. \quad (5)$$

If the expected steady state of the system has a finite frequency content, one may select some of the coefficients in this expansion and get a truncated GSSA expansion. The desired steady state can then be obtained from a regulation problem for which appropriate constant values of the selected coefficients are prescribed. A more mathematically advanced discussion is presented in [14].

In order to obtain a dynamical GSSA model we need the following two essential properties:

$$\frac{d}{dt} \langle x \rangle_k(t) = \left\langle \frac{dx}{dt} \right\rangle_k(t) - jk\omega \langle x \rangle_k(t), \quad (6)$$

$$\langle xy \rangle_k = \sum_{l=-\infty}^{+\infty} \langle x \rangle_{k-l} \langle y \rangle_l. \quad (7)$$

Notice that $\langle x \rangle_k$ is in general complex and that, if x is real,

$$\langle x \rangle_{-k} = \overline{\langle x \rangle_k}. \quad (8)$$

We will use the notation $\langle x \rangle_k = x_k^R + jx_k^I$, where the averaging notation has been suppressed. In terms of these real and imaginary parts, the convolution property (7) becomes (notice that $x_0^I = 0$ for x real, and that the following expressions are, in fact, symmetric in x and y)

$$\begin{aligned} \langle xy \rangle_k^R &= x_k^R y_0^R \\ &+ \sum_{l=1}^{\infty} \{ (x_{k-l}^R + x_{k+l}^R) y_l^R - (x_{k-l}^I - x_{k+l}^I) y_l^I \} \\ \langle xy \rangle_k^I &= x_k^I y_0^R \\ &+ \sum_{l=1}^{\infty} \{ (x_{k-l}^I + x_{k+l}^I) y_l^R + (x_{k-l}^R - x_{k+l}^R) y_l^I \} \end{aligned} \quad (9)$$

Moreover, the evolution equation (6) splits into

$$\begin{aligned} \dot{x}_k^R &= \left\langle \frac{dx}{dt} \right\rangle_k^R + k\omega x_k^I, \\ \dot{x}_k^I &= \left\langle \frac{dx}{dt} \right\rangle_k^I - k\omega x_k^R. \end{aligned} \quad (10)$$

If all the terms in (1) have a series expansion in their variables, one can use (10) and (9) to obtain evolution equations for $x_k^{R,I}$, and then truncate them according to the selected variables. The result is a PCHS description for the truncated GSSA system, to which IDA-PBC regulation techniques can be applied. General formulae for the PCHS description of the full GSSA system, as well as a discussion of the validity of the controller designed for the truncated system, can be found in [3].

III. PCHS MODEL FOR THE GSSA EXPANSION OF THE FULL-BRIDGE RECTIFIER

Figure 1 shows a full bridge AC/DC monophasic boost rectifier, where $v_i = v_i(t) = E \sin(\omega_s t)$ is a monophasic AC voltage source, L is the inductance (including the effect of any transformer in the source), C is the capacitor of the DC part, r takes into account all the resistance losses (inductor, source and switches), and $V = V(t)$ is the DC voltage of the load/output port. The states of the switches are given by s_1, s_2, t_1 and t_2 , with $t_1 = \bar{s}_1, t_2 = \bar{s}_2$ and $s_2 = \bar{s}_1$.

The system equations are

$$\begin{aligned} \dot{\lambda} &= -\frac{S}{C}q - \frac{r}{L}\lambda + v_i \\ \dot{q} &= \frac{S}{L}\lambda + i_i, \end{aligned} \quad (11)$$

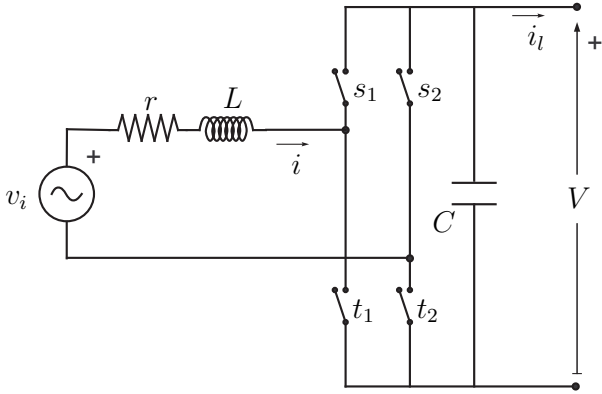

Fig. 1. Full-bridge rectifier with arbitrary load i_l .

where $\lambda = \lambda(t) = Li$ is the inductor linking flux, $q = q(t) = CV$ is the charge in the capacitor, and i_l is the current required at the output port. The discrete variable S takes value $+1$ when s_1 is closed ($v_{s_1} = 0$), and -1 when s_1 is open ($i_{s_1} = 0$).

The control objectives are

- the DC value of V voltage should be equal to a desired constant V_d , and
- the power factor of the converter should be equal to one. This means that the inductor current should be $i = Li_d \sin(\omega_s t)$, where i_d is an appropriate value to achieve the first objective via energy balance.

It is sensible for the control objectives of the problem to use a truncated GSSA expansion with $\omega = \omega_s$, keeping only the zeroth-order average of the dc-bus voltage, q_0 , and the two components of the first harmonic of the inductor current, λ_1^R and λ_1^I . As explained in [6], this selection of coefficients can be further justified if one writes it for $z = \frac{1}{2}q^2$ instead of q , and uses the new control variable $v = -Sq$. In fact, these redefinitions are instrumental in order to fulfill the conditions [3] under which the controller designed for the truncated system can be used for the full system.

With all this, one gets the PCHS

$$\begin{pmatrix} \dot{\lambda} \\ \dot{z} \end{pmatrix} = \begin{pmatrix} -r & v \\ -v & 0 \end{pmatrix} \begin{pmatrix} \partial_\lambda H \\ \partial_z H \end{pmatrix} + i_l \begin{pmatrix} 0 \\ -\sqrt{2z} \end{pmatrix} + v_i \begin{pmatrix} 1 \\ 0 \end{pmatrix}, \quad (12)$$

with Hamiltonian

$$H(\lambda, z) = \frac{\lambda^2}{2L} + \frac{z}{C}. \quad (13)$$

Now we apply an GSSA expansion to this system, and set to zero all the coefficients except for $x_1 \equiv z_0$, $x_2 \equiv \lambda_1^R$, $x_3 \equiv \lambda_1^I$, $u_1 \equiv v_1^R$ and $u_2 \equiv v_1^I$. Using that i_l is assumed to be locally constant, and that the only nonzero coefficient of

v_i is $v_{i1}^I = -\frac{E}{2}$, one gets

$$\begin{aligned} \dot{x}_1 &= -i_l \sqrt{2x_1} - \frac{2}{L} u_1 x_2 - \frac{2}{L} u_2 x_3 \\ \dot{x}_2 &= -\frac{r}{L} x_2 + \omega_s x_3 + \frac{1}{C} u_1 \\ \dot{x}_3 &= -\omega_s x_2 - \frac{r}{L} x_3 - \frac{E}{2} + \frac{1}{C} u_2. \end{aligned} \quad (14)$$

This system can be given a PCHS form

$$\dot{x} = (J(u) - R)(\nabla H)^T + g_1(x_1)i_l + g_2 E,$$

with

$$J = \begin{pmatrix} 0 & -u_1 & -u_2 \\ u_1 & 0 & \frac{\omega_s L}{2} \\ u_2 & -\frac{\omega_s L}{2} & 0 \end{pmatrix} \quad R = \begin{pmatrix} 0 & 0 & 0 \\ 0 & \frac{r}{2} & 0 \\ 0 & 0 & \frac{r}{2} \end{pmatrix}$$

and

$$g_1 = \begin{pmatrix} -\sqrt{2x_1} \\ 0 \\ 0 \end{pmatrix} \quad g_2 = \begin{pmatrix} 0 \\ 0 \\ -\frac{1}{2} \end{pmatrix}$$

and the Hamiltonian function

$$H = \frac{1}{C} x_1 + \frac{1}{L} x_2^2 + \frac{1}{L} x_3^2.$$

This model differs from [6] in the $-i_l \sqrt{2x_1}$ term, that now is included in the g_1 matrix. This change is instrumental in achieving a bidirectional power flow capability, since in [6] $i_l \sqrt{2x_1}$ was included in the dissipation matrix, for which $i_l \geq 0$ was necessary.

The control objectives for this rectifier are a DC value of the output voltage $V = \frac{1}{C}q$ equal to a desired point, V_d , and the power factor of the converter equal to one, which in GSSA variables translates to $x_2^* = 0$. From the dynamical equations we can obtain the equilibrium points,

$$x^* = [x_1^*, 0, x_3^*]$$

where

$$x_1^* = \frac{1}{2} C^2 V_d^2, \quad x_3^* = \frac{\frac{EL}{2r} - \sqrt{\left(\frac{EL}{2r}\right)^2 - \frac{2L^2}{r} i_l V_d}}{2}$$

where we have chosen the smallest of the two possible values of x_3^* .

IV. CONTROLLER DESIGN

The central idea of Interconnection and Damping Assignment-Passivity Based Control (IDA-PBC) [11] is to assign to the closed-loop a desired energy function via the modification of the interconnection and dissipation matrices. The desired target dynamics is a Hamiltonian system of the form

$$\dot{x} = (J_d - R_d)(\nabla H_d)^T \quad (15)$$

where $H_d(x)$ is the new total energy and $J_d = -J_d^T$, $R_d = R_d^T \geq 0$, are the new interconnection and damping matrices, respectively. To achieve stabilization of the desired equilibrium point we impose $x^* = \arg \min H_d(x)$. The

matching objective is achieved if and only if the following PDE

$$(J - R)(\nabla H)^T + g = (J_d - R_d)(\nabla H_d)^T \quad (16)$$

is satisfied, where, for convenience, we have defined $H_d(x) = H(x) + H_a(x)$, $J_d = J + J_a$, $R_d = R + R_a$ and $g = g_1(x_1)i_l + g_2E$.

Fixing the interconnection and damping matrices as $J_d = J$ and $R_d = R$, equation (16) simplifies to

$$-(J - R)(\nabla H_a)^T + g = 0,$$

and, defining $k(x) = (k_1, k_2, k_3)^T = (\nabla H_a)^T$, one gets

$$0 = u_1 k_2 + u_2 k_3 - i_l \sqrt{2x_1} \quad (17)$$

$$0 = -u_1 k_1 + \frac{r}{2} k_2 - \frac{\omega_s L}{2} k_3 \quad (18)$$

$$0 = -u_2 k_1 + \frac{\omega_s L}{2} k_2 + \frac{r}{2} k_3 + \frac{E}{2}. \quad (19)$$

Equations (18) and (19) can be solved for the controls,

$$u_1 = \frac{rk_2 - \omega_s L k_3}{2k_1} \quad (20)$$

$$u_2 = \frac{\omega_s L k_2 + rk_3 + E}{2k_1}, \quad (21)$$

and replacing (20) and (21) in (17) the following PDE is obtained:

$$r(k_2^2 + k_3^2) + Ek_3 - 2i_l \sqrt{2x_1} k_1 = 0. \quad (22)$$

If one is interested in control inputs u_1 and u_2 which only depend on x_1 , one can take $k_1 = k_1(x_1)$, $k_2 = k_2(x_1)$ and $k_3 = k_3(x_1)$, and consequently, using the integrability condition

$$\frac{\partial k_i}{\partial x_j}(x) = \frac{\partial k_j}{\partial x_i}(x)$$

one gets that $k_2 = a_2$ and $k_3 = a_3$ are constants. Then, from (22),

$$k_1 = \frac{1}{2i_l \sqrt{2x_1}} (r(a_2^2 + a_3^2) + Ea_3). \quad (23)$$

The equilibrium condition

$$\nabla H_d|_{x=x^*} = (\nabla H + \nabla H_a)|_{x=x^*} = 0$$

is

$$\begin{aligned} \frac{1}{C} + k_1(x_1^*) &= 0 \\ \frac{2}{L}x_2^* + a_2 &= 0 \\ \frac{2}{L}x_3^* + a_3 &= 0 \end{aligned} \quad (24)$$

and, since $x_2^* = 0$, one obtains $a_2 = 0$ and $a_3 = -\frac{2}{L}x_3^*$. Substituting these values of a_2 and a_3 in (23) yields

$$k_1 = -\frac{1}{C} \sqrt{\frac{x_1^*}{x_1}} \quad (25)$$

which satisfies the equilibrium condition (24). One can now solve the PDE (22) and find H_a

$$H_a = -\frac{2\sqrt{x_1^*}}{C} \sqrt{x_1} - \frac{2}{L} x_3^* x_3, \quad (26)$$

from which

$$H_d = \frac{1}{C}x_1 + \frac{1}{L}x_2^2 + \frac{1}{L}x_3^2 - \frac{2\sqrt{x_1^*}}{C}\sqrt{x_1} - \frac{2}{L}x_3^*x_3. \quad (27)$$

In order to guarantee that H_d has a minimum at $x = x^*$, the Hessian of H_d has to obey

$$\left. \frac{\partial^2 H_d}{\partial x^2} \right|_{x=x^*} > 0.$$

From (27)

$$\left. \frac{\partial^2 H_d}{\partial x^2} \right|_{x=x^*} = \begin{pmatrix} \frac{1}{2C\sqrt{x_1^*}} & 0 & 0 \\ 0 & \frac{2}{L} & 0 \\ 0 & 0 & \frac{2}{L} \end{pmatrix},$$

which is always positive definite, so the minimum condition is satisfied. Substituting everything in (20), (21), the control laws can be expressed in terms of the output voltage V :

$$u_1 = -\frac{2\omega_s C x_3^* V}{V_d} \quad (28)$$

$$u_2 = -\frac{CLi_l V}{2x_3^*}. \quad (29)$$

Writing (28) and (29) in real coordinates, using the inverse GSSA transformation

$$u = 2(u_1 \cos(\omega_s t) - u_2 \sin(\omega_s t)),$$

and taking into account that $u = -S\sqrt{2x_1}$, the control action simplifies finally to

$$S = \frac{2\omega_s x_3^*}{V_d} \cos(\omega_s t) - \frac{Li_l}{x_3^*} \sin(\omega_s t).$$

V. SIMULATIONS

In this section we implement a numerical simulation of the IDA-PBC controller for a full-bridge rectifier. We use the following parameters: $r = 0.1\Omega$, $L = 1\text{mH}$, $C = 4500\mu\text{F}$, $\omega_s = 314\text{rad s}^{-1}$ and $E = 68.16\text{V}$. The desired voltage is fixed at $V_d = 150\text{V}$, and the load current varies from $i_l = -1\text{A}$ to $i_l = 3\text{A}$ at $t = 1\text{s}$. Figure 2 shows the bus voltage V . It starts at $V = 140\text{V}$ and then goes to the desired value, for different load current values. The small static error corresponds to the non-considered harmonics in the control design using GSSA. AC voltage and current are depicted in Figure 3. Notice that when $i_l > 0$ (for $t < 1$), current i is in phase with voltage v_i and power flows to the load; when $i_l < 0$ (for $t > 1$), i is in opposite phase with v_i and power flows from the load to the AC main. Finally, Figure 4 shows that the control action S remains in $[-1, 1]$, which allows its implementation using a PWM scheme.

VI. CONCLUSIONS

A controller able to achieve bidirectional power flow in a full-bridge boost-like rectifier has been presented and tested under numerical simulation. The controller has been designed using IDA-PBC techniques for a suitable PCHS-GSSA truncated model of the system. The control scheme achieves good regulation of the dc bus and high power factor from the ac side. Work to test this controller in experiment is

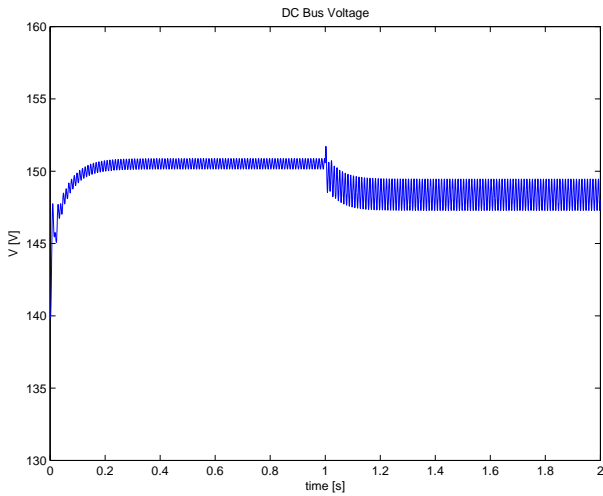

Fig. 2. Simulation results: bus voltage V waveform.

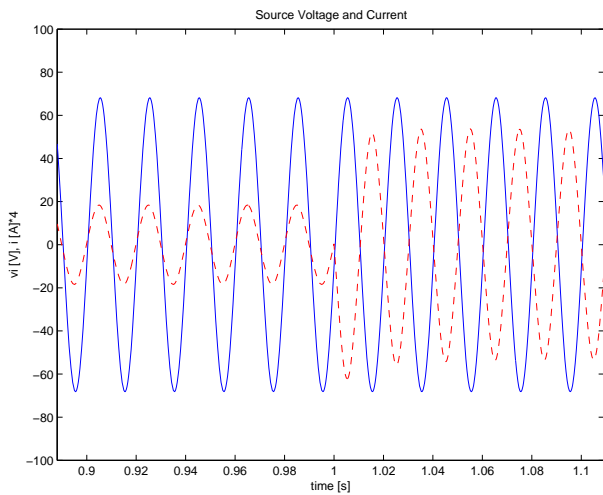

Fig. 3. Simulation results: source voltage v_i and current i waveforms, showing the change in power flow.

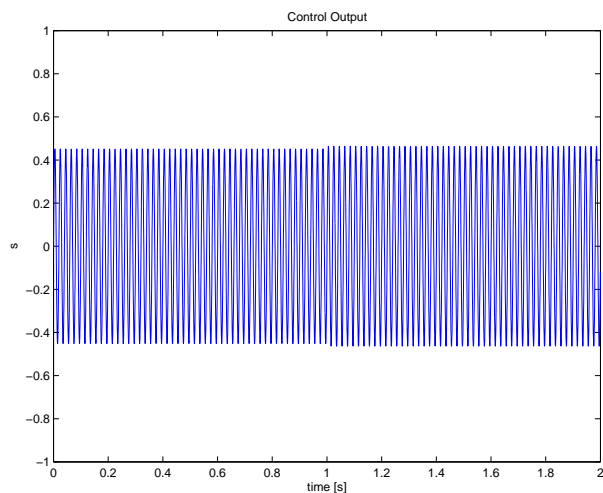

Fig. 4. Simulation results: control action S remains in $[-1, 1]$.

in progress. Further improvements of the controller, namely consideration of higher harmonics of the dc voltage and additional damping injection, are also under study.

REFERENCES

- [1] C. Batlle, A. Dòria-Cerezo, and E. Fossas. Bidirectional power flow full-bridge rectifier. In preparation.
- [2] C. Batlle, A. Dòria-Cerezo, and R. Ortega. Power Flow Control of a Doubly-Fed Induction Machine Coupled to a Flywheel. In *IEEE Proc. Conference on Control Applications*, pages 1645–1651, 2004.
- [3] C. Batlle, E. Fossas, R. Griñó, and S. Martínez. Generalized state space averaging for port controlled hamiltonian systems. Technical report, Universitat Politècnica de Catalunya, 2005. Accepted for presentation at 16th IFAC World Congress, Prague, July 4-8 2005.
- [4] V.A. Caliskan, G.C. Verghese, and A.M. Stankovic. Multi-frequency averaging of dc/dc converters. *IEEE Transactions on Power Electronics*, 14(1):124–133, January 1999.
- [5] M. Dalsmo and A. van der Schaft. On representations and integrability of mathematical structures in energy-conserving physical systems. *SIAM J. Control Optim.*, (37):54–91, 1998.
- [6] C. Gaviria, E. Fossas, and R. Griñó. Robust controller for a full-bridge rectifier using the IDA-PBC approach and GSSA modelling. *IEEE Trans. Circuits and Systems I*, in press.
- [7] P.T. Krein, J. Bentsman, R. M. Bass, and B. L. Lesieutre. On the use of averaging for the analysis of power electronic systems. *IEEE Transactions on Power Electronics*, 5(2):182–190, April 1990.
- [8] A. Kugi. *Non-linear control based on physical models*. Springer, 2001.
- [9] J. Mahdavi, A. Emaadi, M. D. Bellar, and M. Ehsani. Analysis of power electronic converters using the generalized state-space averaging approach. *IEEE Transactions on Circuits and Systems I*, 44(8):767–770, August 1997.
- [10] R. Ortega, A. van der Schaft, I. Mareels, and B. Maschke. Putting energy back in control. *IEEE Control Systems Magazine*, 21:18–33, 2001.
- [11] R. Ortega, A. van der Schaft, B. Maschke, and G. Escobar. Interconnection and damping assignment passivity-based control of port-controlled Hamiltonian systems. *Automatica*, (38):585–596, 2002.
- [12] Seth R. Sanders, J. Mark Noworolski, Xiaojun Z. Liu, and G.C. Verghese. Generalized averaging method for power conversion circuits. *IEEE Transactions on Power Electronics*, 6(2):251–259, April 1991.
- [13] H. Sira-Ramírez, R.A. Pérez-Moreno, R. Ortega, and M. Garcia-Esteban. Passivity-based controllers for the stabilization of dc-to-dc power converters. *Automatica*, 33(4):499–513, 1997.
- [14] G. Tadmor. On approximate phasor models in dissipative bilinear systems. *IEEE Trans. on Circuits and Systems I*, 49:1167–1179, 2002.
- [15] A. van der Schaft. *L₂ gain and passivity techniques in nonlinear control*. Springer, 2 edition, 2000.
- [16] A. van der Schaft and B. Maschke. Port controlled hamiltonian systems: modeling origins and system theoretic properties. In *Proc. 2nd IFAC Symp. on Nonlinear Control Systems Design (NOLCOS'92)*, pages 282–288, 1992.
- [17] X. Yu and J.X. Xu, editors. *Advances in Variable Structure System, Analysis, Integration and Applications*. World Scientific, Singapur, 2001.